

WINEGARD®

Movin' View™

**Digital Satellite Mobile Antenna for Single Receiver
for Use While Stationary or In-Motion
Model MV-4000**

Made in the U.S.A. U.S. Patent Nos. 6,023,247; 6,188,300

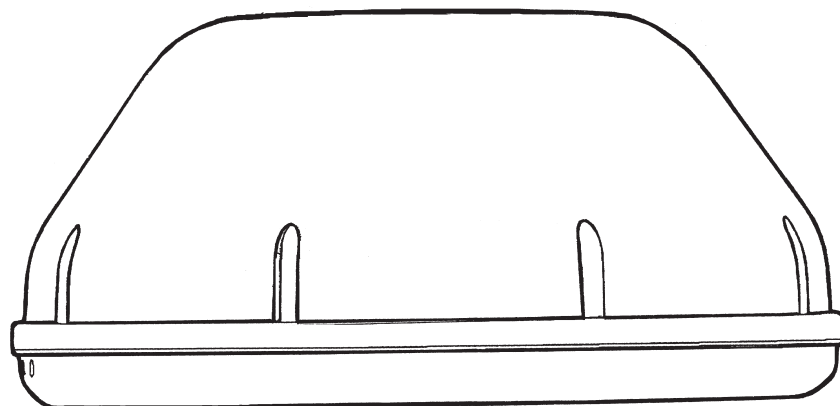
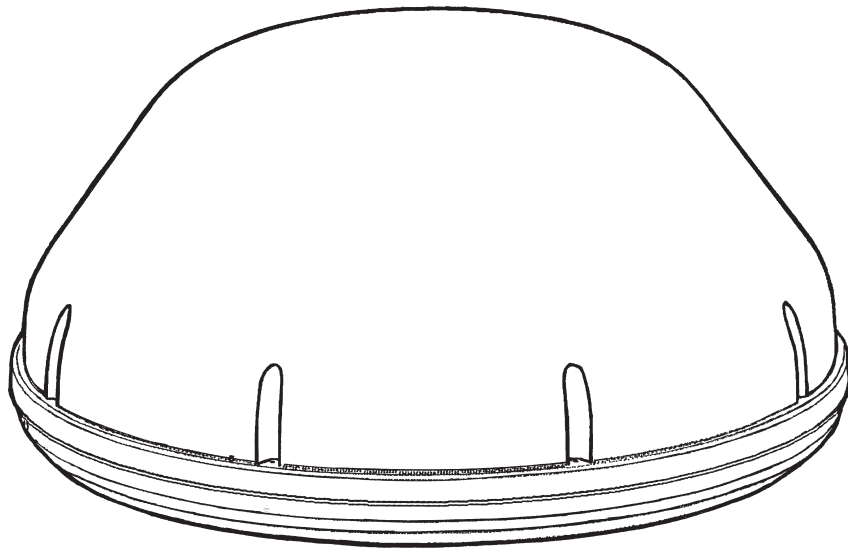

Winegard Company • 3000 Kirkwood St. • Burlington, IA 52601-2000
319/754-0600 • FAX 319/754-0787 • www.winegard.com
Printed in U.S.A. © Winegard Company 2005 2452065 Rev. 5/05

Introduction/How Does Digital Satellite TV Work?

About this manual — We hope this manual will provide clear instructions to install and operate MV-4000. Two symbols have been used —



Indicates caution should be taken!



Indicates suggestions to make processes easier for you.

Introduction

Congratulations! You have purchased one of Winegard's latest developments in the mobile satellite reception product line — the Movin' View™. This system, used with your digital satellite receiver, will deliver the best reception possible using GPS (Global Positioning System) and precision gyroscopes.

How Does Digital Satellite TV Work?

Satellite programming originates from an "uplink" facility on Earth — the facility receives many signals from different sources, combines the signals digitally and transmits to the satellites. The satellites (22,300 miles above Earth) receive the uplink signal, amplify it and then transmit it back to earth in the Ku frequency band. This signal is concentrated and reflected to the LNBF* located at the "focal point" of the dish. The LNBF amplifies and converts the signal to the 950 to 1450 MHz range. The signal is then passed through a coaxial cable to the receiver where individual channel selection and processing take place.

* Low Noise Block Converter Feed

For Programming information call:

DISH NETWORK® - 1-800-333-DISH (1-800-333-3474)

DIRECTV® - 1-800-DIRECTV (1-800-347-3288)

EXPRESSVU® - 1-888-SKYDISH (1-888-759-3474)

Your new Winegard RV Digital Satellite System is an easy-to-use satellite TV reception system. Because it mounts on the top of your recreational vehicle, it goes where you go and provides quality reception of digital satellite signals. Check with your program provider for exact coverage area.

MV-4000 features:

- GPS technology
- Easy "one-button" operation
- Compatible with most digital satellite receivers
- Ability to toggle between satellites using remote control, if subscribing to multisatellite programming
- Winegard warranty

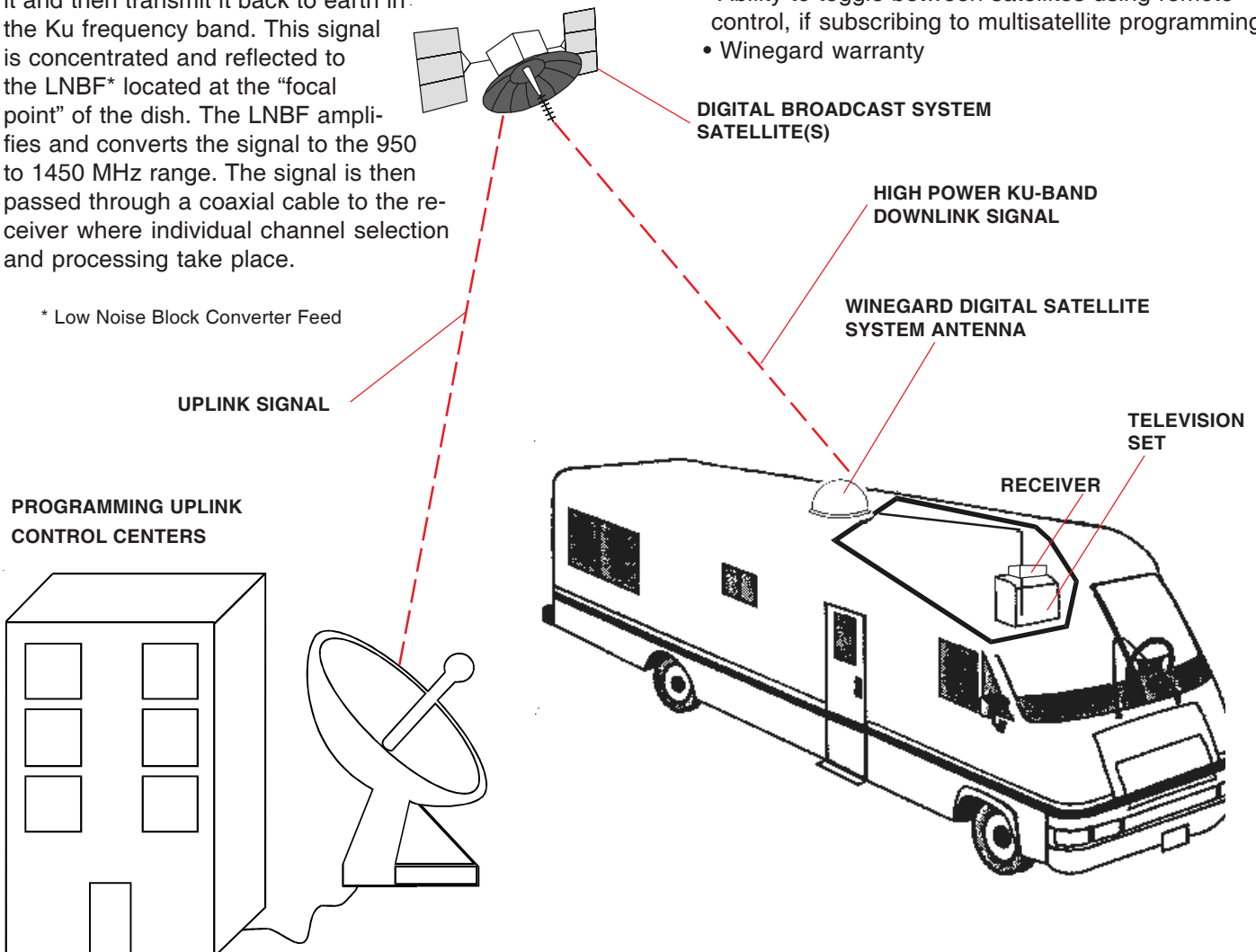

Quick Reference Guide

NOTICE!

This model is PRESET for DIRECTV® receivers
Mounting Option A.

If you have a DISH Network® or ExpressVu® (Canada) receiver, or you choose Mounting Option B, you must change the numbered switches inside the dome.

TO CHANGE SWITCHES INSIDE DOME —

1. Remove tapes holding dome to base and remove dome. Place dome in safe spot to avoid damage. Switches will be set at 101° for DIRECTV®. You will be changing these switches.

MOUNTING OPTION A

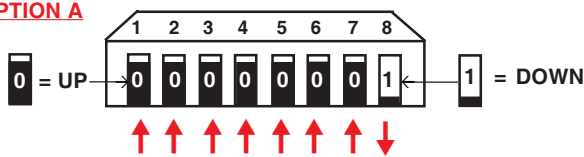

		(#1 represents Switch DOWN; #0 represents Switch up)							
Sat. Rcvr.	Mt. Option	1	2	3	4	5	6	7	8
DIRECTV	A	0	0	0	0	0	0	0	1
(FACTORY PRESET)									
DIRECTV	B	1	0	0	0	0	0	0	1
DISH NETWORK	A	0	0	0	1	0	0	1	1
DISH NETWORK	B	1	0	0	1	0	0	1	1
ExpressVu	A	0	1	0	1	1	0	1	1
ExpressVu	B	1	1	0	1	1	0	1	1

MOUNTING OPTIONS SHOWN BELOW

0= UP 1= DOWN

2. Determine which programming you will be using. This will determine how you set your switches.

For DISH Network set switches to 119°.

For ExpressVu®, set switches to 091°.

MOUNTING OPTION A

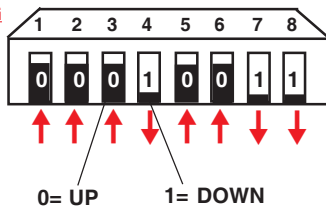

MOUNTING OPTION A

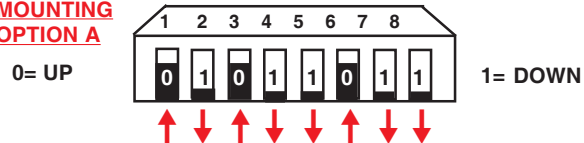

0= UP 1= DOWN

MOUNTING OPTIONS A AND B

FIGURE 1A, OPTION A

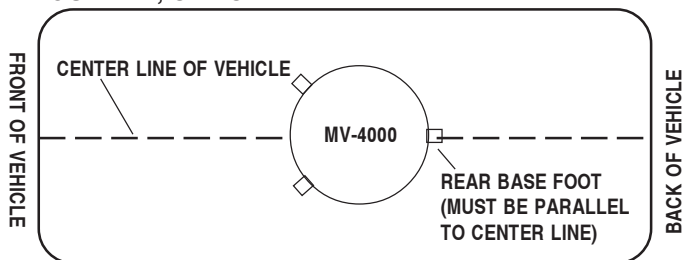
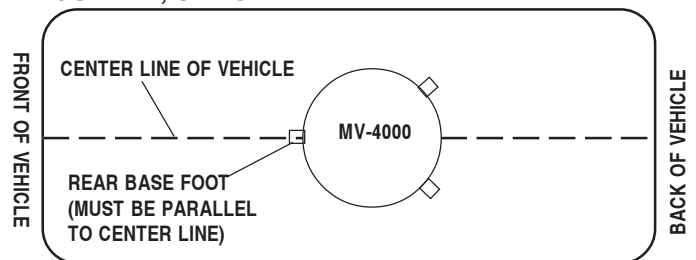

FIGURE 1B, OPTION B



DIRECTV® receivers must be set to the two satellite, oval dish setting. Refer to your receiver manual.

DISH Network® receivers must either have the check switch set for SW42 or unknown, no satellite found. See page 5.

The satellite system has two modes of operation; **Tracking Mode** and **Sleep Mode**. When you first turn the unit on it enters **Tracking Mode**. (The unit will not toggle in Tracking Mode, see page 5.) In this mode, the unit will search and actively follow the satellite as the vehicle travels. Tracking Mode ends when the unit has successfully finished its search and the vehicle has not moved for six minutes.

Sleep Mode is the unit at rest mode. During Sleep mode the dish will toggle between primary and secondary satellites as you change channels with the remote. The unit enters Sleep mode about six minutes after a successful search if stationary, or six minutes after the vehicle stops moving. (See page 5.)

Operation

1. Turn on receiver and television set. **The MV-4000 must be connected to a receiver that is plugged into 120 VAC.**

2. **Verify that you are getting the receiver's** menu screens on the television. These screens are available with or without the dish finding the signal.

3. **Turn the power switch on for the MV-4000.**

The dish should start moving, making one or two revolutions before it stops to acquire GPS. This can take a few moments or up to 10-15 minutes. **Normal operation will be less than a minute.**

4. **Once the unit has acquired GPS, the dish will begin its search.**

The dish will pause on the signal long enough to determine which satellite it has found.

If it moves off the signal, it is in an effort to verify the signal and it should return to the signal shortly.

5. After the unit has verified that it has the correct satellite, it will continue to track the signal.

6. If the vehicle does not move for 6 minutes the unit will toggle to it's alternate satellite then toggle back to the primary satellite and go to sleep. Refer to page 3 for a description of Sleep Mode. If vehicle begins movement, the unit will resume tracking mode.

7. While the vehicle is in motion, the unit will not enter sleep mode after a successful search. Instead it will wait until the unit has stopped moving for 6 minutes before entering sleep mode.

8. **If you do not have signal**, see *Troubleshooting*, p. 11.

Recovery From Signal Interruption—

While traveling, the signal will be interrupted when the line of sight to the satellite is blocked.

Signal is acquired again after line of sight is restored. If signal is interrupted for more than 15 seconds, the system automatically enters the search routine. ***The length of time for the TV picture to recover depends on the receiver model you are using.***



Must drive in straight line for 10 seconds when starting to operate in motion.

To toggle between satellites when subscribing to multi-satellite programming—

While in **Sleep Mode**, the MV-4000 will toggle between the primary and secondary satellites for either DISH Network or DIRECTV. Both have programming on more than one satellite. When a channel is selected on the remote control and is not on the satellite currently selected, the unit will automatically move to the correct satellite.

DIRECTV programming

1. DIRECTV receivers must be set for oval dish 2 sat selection to enable toggling between primary 101°W satellite and alternate 119°W satellite only. (Consult receiver manual for procedure.) After receiver is set for the correct dish selection, when you request a channel located on a different satellite, the unit will automatically move to that satellite.

DISH Network programming (DISH 500)

DISH Network receivers must have the “SW42” switch installed in order to toggle between the primary 119 satellite and the alternate 110 satellite. (Consult your receiver manual for the procedure to reach the “check switch” menu.)

To install the “SW42” switch:

1. Before turning on your MV-4000 system, make sure that your satellite receiver and television are turned on and your receiver is on the “point dish” menu. (Consult your owner’s manual to reach this menu.)
2. While the vehicle is stationary, turn on the MV-4000 system and wait for signal acquisition on satellite 119.
3. After signal is acquired, the system will continuously track the signal for approximately 6 minutes. At the end of 6 minutes, the unit will enter sleep mode. You now have 6 minutes to complete Check Switch test. Consult your receiver manual for instructions on running this test. Be sure that Superdish and Alternate are unchecked if applicable. Onscreen options may vary by receiver.
4. During the Check Switch Test, the receiver will begin checking the switch by toggling between satellites. When this is completed, SW42 will appear on the screen. It will be at the top of the screen, satellite designations will be below, showing odd and even transponders. See illustration.

If a switch other than SW42 appears, or you have an X in one of the boxes below the satellites, repeat Check Switch Steps.

5. Your system is now set up to toggle between satellites. It will automatically move to the correct satellite when a channel is selected with your remote control.

NOTE: Once these steps are completed, you won’t have to perform this test again, unless Check Switch was performed on another satellite dish, such as a home dish.



Toggle: Your Winegard Automatic satellite dish will move from the primary to the alternate satellite in order to receive multi-satellite programming.

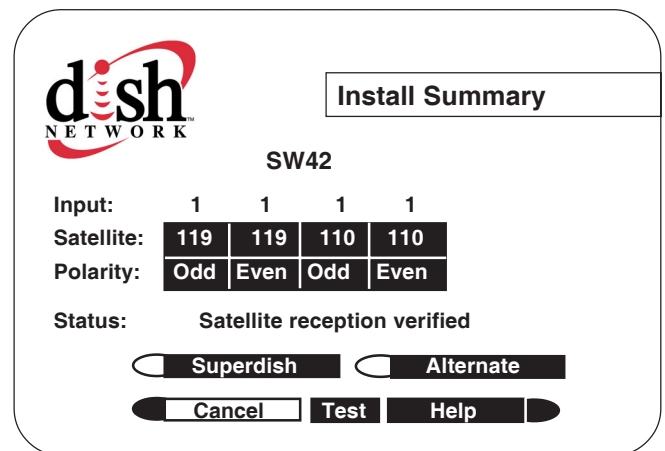

Check Switch screen display

NOTE: Be sure the “Superdish” and “Alternate” boxes ARE NOT checked.

Parts Included • Tools Needed • How to Unpack

PARTS INCLUDED:

1 Radome
1 Power switch
1 Wall plate (white)
1 Surface mount box
1 Cable entry plate
2 Cable ties
3 Base feet
1 Coax connector

1 Barrel connector
1 large yellow spade connector
2 small red spade connectors
All required screws, washers, bolts, and nylocks
1 base with electronics, dish, single LNBF
Silicone sealant
Surface Wipes
30' power cable and 30' coaxial cable

TOOLS NEEDED FOR UNPACKING & INSTALLATION:

Level
Drill w/3/4" bit
1-1/4" hole saw (if mounting switch in wall)
Phillips screw driver #2

3/8" Open end wrench
7/16" Open end wrench
Sealant (consult RV manufacturer for proper type for your roof material)

UNPACKING THE UNIT

1. Open box and remove packing material.



If using knife to open carton, **BE CAREFUL**. Do not cut the dome on the unit.



BE CAREFUL when removing unit. Dome is attached to base by only 3 pieces of tape, **NOT BY SCREWS**.

2. Lift dome out of box vertically. Then lift unit out of box vertically. **Do not turn box and "roll" out, or turn upside down to remove.**



USE 2 PEOPLE when removing the unit from the carton.



DO NOT PAINT DOME! Painting dome will cause signal degradation.

**LIFT UNIT STRAIGHT UP
OUT OF CARTON!**

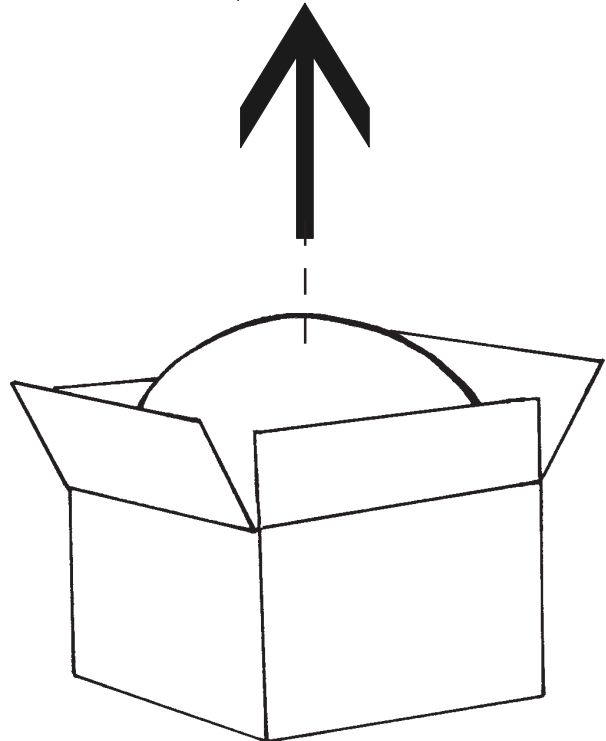

Base Diagram

FIGURE 2

SWITCH LOCATION
(SIDE OF BOX, SEE PAGE 3)

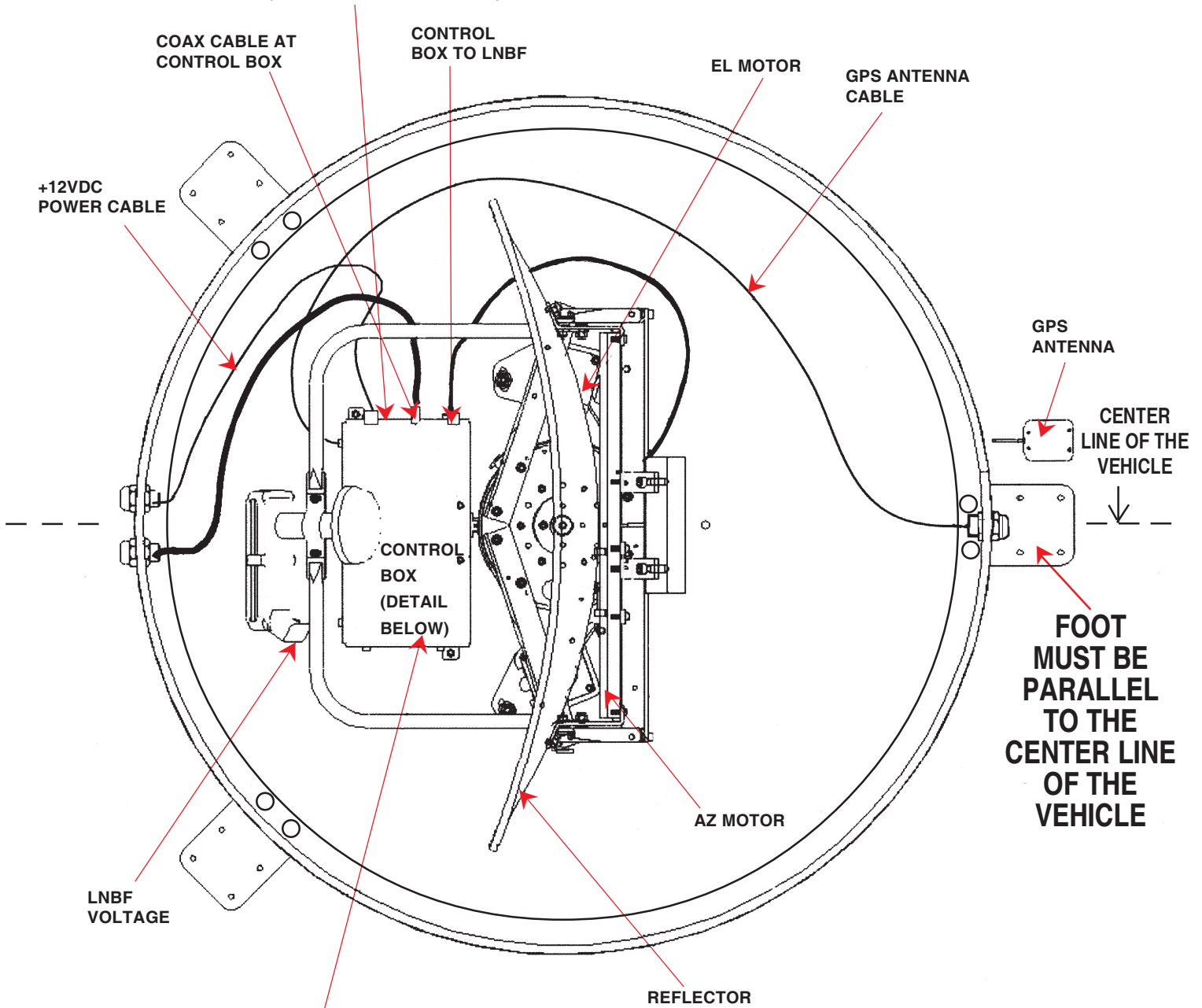

CONTROL BOX DETAIL

Vehicle Front



Mount Option A

Vehicle Front



Mount Option B

(#1 represents Switch DOWN; #0 represents Switch up)

Sat. Rcvr.	Mt. Option	Switch Set Position							
		1	2	3	4	5	6	7	8
DIRECTV	A	0	0	0	0	0	0	0	1
(FACTORY PRESET)									
DIRECTV	B	1	0	0	0	0	0	0	1
DISH NETWORK	A	0	0	0	1	0	0	1	1
DISH NETWORK	B	1	0	0	1	0	0	1	1
ExpressVu	A	0	1	0	1	1	0	1	1
ExpressVu	B	1	1	0	1	1	0	1	1

12VDC

COAX TO RECEIVER

COAX TO LNBF

P4

ELEVATION

P3

AZIMUTH

ELECTRONICS INTERIOR VIEW

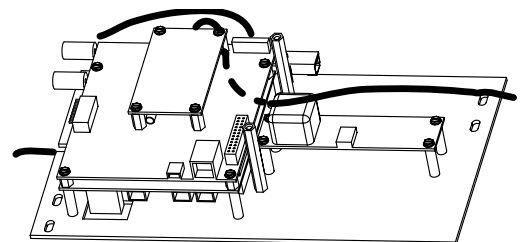

Installing unit on roof of vehicle —

Install in DRY conditions only!



IMPORTANT! Do not install this system in the rain, or under any wet conditions. Moisture may affect electronics and void your warranty!

1. For best performance and to reduce signal acquisition time, park vehicle on a level surface; level the RV.
2. Select a level spot on your roof for installation.

Using the chart, determine the **minimum** distances to other equipment.

Obstruction Ht.	Unit Clearance
8"	4"
10"	11.5"
12"	19"
15"	32"

FIGURE 3

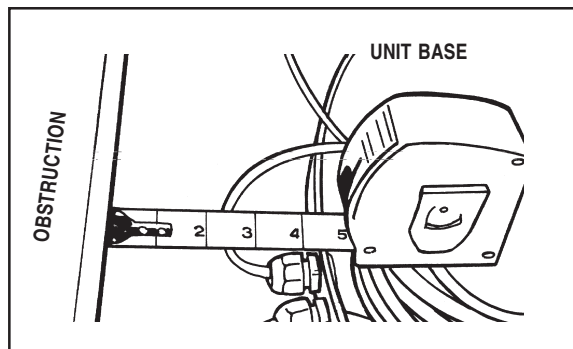

WARNING: Level the base front to back and side to side. If base is not level the MV-4000 may require more time to locate the correct satellite or may not locate the correct satellite.

- Be sure no roof-mounted equipment is blocking the satellite "line of sight", Fig. 3
- You will need to decide where the wires will enter the vehicle. A coax and a power wire (minimum 16 gauge) will need to be run into the vehicle.

WARNING: Many +12VDC sources can cause the unit to fail. Select a filtered source, preferably a dedicated line to the battery.

3. Remove dome. Place dome in safe spot to avoid damage. Place base on vehicle roof in the location selected.
4. Attach each mounting foot to base by securing with two 7/16" nylocks. See page 7 for foot locations.
5. After selecting location for unit (see number 2), put the unit on the centerline of the vehicle.

REAR MOUNTING FOOT MUST BE PARALLEL WITH THE CENTER LINE OF VEHICLE. See pg. 7.

6. Place the unit on the roof in its permanent location and mark around the base bracket, Figure 4. (Make sure the **rear adjustable base foot is parallel with the center line of the vehicle.** Refer to page 3, Figure 1A).

FIGURE 4

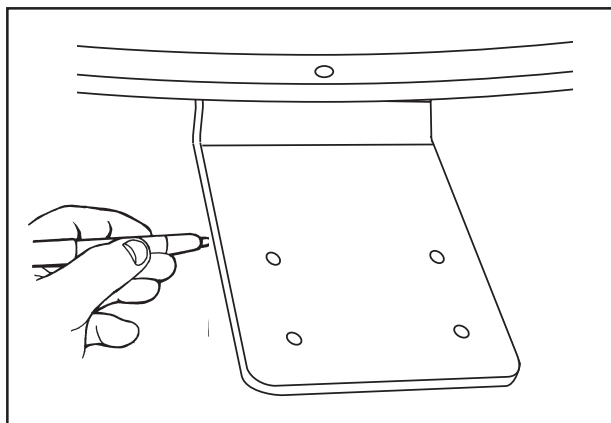

7. Clean roof area where the base feet will be attached to the roof. Do not erase your marks!

8. Put approved sealant in the areas marked for the base feet. Place base feet on top of the sealant and screw down with the (4) #10 screws (provided) for each foot.

9. After all base feet are secured to roof, put sealant around edge of feet and over screws. Replace base on screws and reinstall nut.

FIGURE 5

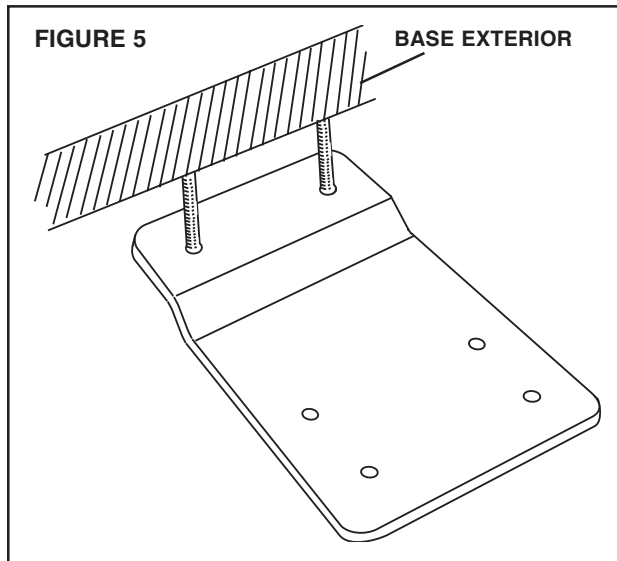

Installation

GPS installation —

10. The GPS antenna is pre-wired and has a 1 meter cable running through one of the connectors.

Determine location for GPS antenna. It is recommended you place the GPS antenna 3 feet from dome.

The recommended location for the GPS antenna is based on having a level location and a clear view of the sky for the best satellite signal acquisition. Do not secure GPS antenna to roof at this time.

IMPORTANT! The GPS must be located minimum of 3 feet away from obstructions on roof of vehicle. **Antenna must have a clear view of the sky for proper operation.**

Cable entry installation —

1. Decide the best **location for the cables** to enter the vehicle, *and* the **location of the switch and receiver** (see “Installing the switch and receiver” on page 10). Drill a 1/2” hole in the roof, push wires inside. Make proper connections.

You must have filtered +12 VDC power source.

2. Place cable-entry plate over hole and cables. Screw in place. Seal plate and screw holes with approved sealant (not included).

3. Depending on the length of the cable on the roof, you may need to use cable clamps or wire ties (not provided) between the unit and your cable-entry plate. Clamping the cable every 12”-16” should eliminate any unnecessary cable movement, Figure 6.

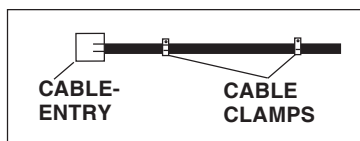
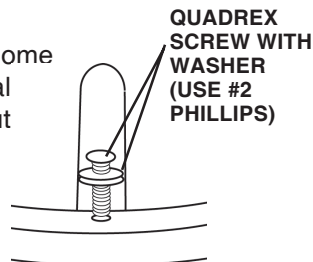

FIGURE 4

INSTALLING THE DOME

Insert screw in holes on dome rim. Be sure bolt is vertical not tilted to side. Place nut under rim and tighten.



CAUTION:
DO NOT
OVERTIGHTEN!!

INSTALLING THE POWER SWITCH

1. Choose a location to install the MV-4000 power ON/OFF switch. Remember when selecting a location that you will need to run the +12VDC power cable from the MV-4000 to the switch. **Be sure the switch is in the OFF position before continuing.** See Figure 9 page 10.

Wall or panel mount: Drill 1-1/4” hole, pull wires through wall or panel.

Surface mount: Determine location and direction of box. Mount box and feed wire into one of the box openings. Select plate cover (brown or white provided) and snap the rocker switch into the switch plate. Be sure switch is off!

2. Connect the ground wire from the vehicle and the BLACK ground wire from the MV-4000 together, using large yellow spade connector.
3. Connect the YELLOW spade connector to the silver spade on the switch.
4. Connect the RED wire from the MV unit to the small RED spade connector.
5. Connect small RED spade connector to center spade on switch.
6. Connect the +12 V power wire from the vehicle to a small RED spade connector.
7. Connect small RED spade connect to isolated spade on switch.

INSTALLING THE POWER SWITCH DIAGRAM

FIGURE 5

ON/OFF ROCKER SWITCH WITH LIGHT
(Shown in OFF position.)

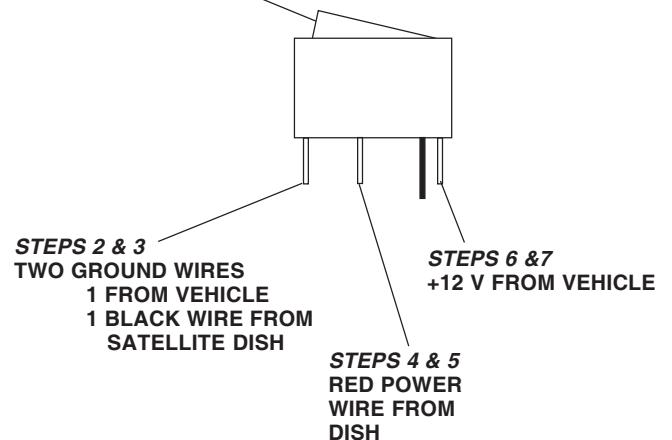

Terminals on switch have to be bent to fit in surface mount box.

CONNECTING THE RECEIVER —

Connect the coax cable from the roof to the “Satellite In” connection on the receiver.

(A dual receiver upgrade kit is available. Contact Winegard Company for more information.)

INITIALIZING ---

1. Be sure vehicle is in a location free of all obstructions and with a clear view of the southern sky.
2. **DO NOT MOVE VEHICLE** during the first initialization. Power up unit, turn on receiver. **FOR THE FIRST TIME ONLY**, the unit may take up to 10 minutes to initially find the satellite signal. The GPS is also initializing at this time. After the GPS initializes, the unit will begin searching for the correct satellite. See page 4 for details of Operation.
3. **If the GPS does not initialize at this time**, turn off the unit. You may need to move the GPS antenna to a different location on your roof. After you move the GPS, **DO NOT SECURE TO ROOF**.
4. **TEST YOUR SYSTEM BEFORE SECURING THE GPS ANTENNA.** Verify that the dish has found the correct satellite by checking the receiver’s signal meter screen.
5. After the correct satellite has been found, **secure GPS antenna by removing adhesive backing and securing to roof.**

PROBLEM

SOLUTION

<p>The MV-4000 does not attempt to find a satellite or it never moves.</p>	<ol style="list-style-type: none"> 1. Check your Power switch to verify that it is in the ON position. 2. Check +12 V wires at unit to verify power. Check fuse on electronics. 3. Verify that the MV-4000 has had its shipping straps removed. These straps are located inside the dome and keep the dish from moving until it is installed.
<p>The MV-4000 turns on and moves for a few seconds then stops and never moves again.</p>	<ol style="list-style-type: none"> 1. Wait 10 minutes. The unit can take up to 10 minutes to acquire GPS. If it normally takes 10 minutes to acquire GPS, contact Winegard. 2. If you feel comfortable doing so, look on the roof of the vehicle to verify that the GPS antenna is at least 3 feet from the dome and other objects on roof. Failure to have the GPS antenna at least 3 feet away can cause the dome to interfere with GPS acquisition. If antenna is too close, move it. 3. Check the GPS antenna cable for damage. If there is a pinched or damaged section, contact Winegard.
<p>The dish never stops on any of the signals that it sees.</p>	<ol style="list-style-type: none"> 1. Make sure that your receiver is set up correctly. For DISH Network, the check switch should read either “Unknown” or “SW42”. For DirecTV the receiver should be set for a Two Satellite Oval Dish. 2. Make sure the receiver has power and the satellite dish is connected to the “Sat In”.
<p>With DIRECTV, the dish will find the alternate Satellite but it never finds the primary satellite.</p>	<p>Make sure that the Switches on the Electronics Control Box are set for DirecTV. See page 3. These switches are found under the dome, inside the Electronics Control Box.</p>
<p>The dish stopped searching and is making little circles in the same area but I don't have a signal.</p>	<ol style="list-style-type: none"> 1. Most likely the dish has locked on the satellite. Sometimes the receiver refuses to show it until its ready. To help it get ready, turn the receiver, not the dish, OFF. Wait a few minutes and turn it back on. 2. For Dish Network users, the Dish might be set to find DirecTV. See page 3 for instructions on setting it for Dish Network.
<p>I am not getting all the DISH Network channels I subscribed to.</p>	<ol style="list-style-type: none"> 1. Go to the check switch menu in receiver. Make sure that it's set for SW42 and lists both even and odd transponders on satellites 110 and 119.
<p>The MV-4000 never sees any signals, it just keeps searching.</p>	<ol style="list-style-type: none"> 1. Rain, Snow or excessive Dew on the dome can interrupt the signal. Snow and Dew can be brushed off the dome. If Heavy rain or Snow fall is blocking the signal, it may be necessary to wait until the weather clears. 2. Check to see if the Southern sky is clear. Trees, Buildings, Large signs or an Overpass can block the signal. Find an area where you can be sure that this is not the problem and try again. 3. Make sure the receiver has power and the satellite dish is connected to the “Sat In”. 4. Verify electronics board inside dome is installed in proper location. Board should be placed so that magnets on unit's gears pass through electronics board slot without hitting interior boards.
<p>The MV-4000 works when it is stationary but fails when the vehicle is in motion.</p>	<p>Verify that the switches are set for the install option used for your vehicle. Option A has the rear mounting foot facing off the back of the vehicle. Option B has the rear mounting foot facing off the front of vehicle. See page 3 for switch settings.</p>

Specifications & Warranty

Features and specifications

- One button operation.
- GPS satellite signal acquisition.
- Depending on receiver type, you can access satellites 119°, 110°, 101° or 92°.
- No user input required.
- No data port required for DISH Network®, DIRECTV® or ExpressVu.
- Tracking greater than 30°/sec.
- Elevation range 18° to 74.5°; azimuth unlimited.
- 30' power cable and 30' coaxial cable included.
- Dome UV protected.
- White color compatible with all vehicles.
- Compact size —
32" diameter, 15-3/4" height
Weight of unit - 32 lbs.
Shipping weight - 44 lbs.
- Operating temperature
-13°F to +140°F

TWO YEAR LIMITED WARRANTY

Winegard Company warrants this Winegard product (excluding receiver) against any defects in materials or workmanship within two (2) years from date of purchase. No warranty claim will be honored unless at the time the claim is made, you present proof of purchase to an authorized Winegard dealer (if unknown, please contact Winegard Company, 3000 Kirkwood Street, Burlington, Iowa 52601-2000, telephone 319-754-0600).

Winegard Company (at its option) will either repair or replace the defective product at no charge to you. This warranty covers parts, but does not cover any costs incurred in removal, shipping or reinstallation of the product. This limited warranty does not apply if the product is damaged, deteriorates, malfunctions or fails from: misuse, improper installation, abuse, neglect, accident, tampering, modification of the product as originally manufactured by Winegard, usage not in accordance with product instructions or acts of nature such as damage caused by wind, lightning, ice or corrosive environments such as salt spray and acid rain.

The Two Year Warranty is provided on the condition that the equipment is properly delivered with all handling and freight charges prepaid to your Winegard dealer for repair or return to our factory at the above address. Winegard dealers will arrange for the replacement or repair and return to you, without charge, the product which failed due to defective material or workmanship.

WINEGARD COMPANY WILL NOT ASSUME ANY LIABILITIES FOR ANY OTHER WARRANTIES, EXPRESS OR IMPLIED, MADE BY ANY OTHER PERSON.

ALL OTHER WARRANTIES WHETHER EXPRESS, IMPLIED OR STATUTORY INCLUDING WARRANTIES OF FITNESS FOR A PARTICULAR PURPOSE AND MERCHANTABILITY ARE LIMITED TO THE TWO YEAR PERIOD OF THIS WRITTEN WARRANTY.

The foregoing shall be the sole and exclusive remedy of any person whether in contract, tort or otherwise, and Winegard shall not be liable for incidental or consequential damage or commercial loss, or from any other loss or damage except as set forth above.

Some states do not allow limitations on how long an implied warranty lasts, or the exclusion of limitation of incidental or consequential damages, so the above limitations or exclusions may not apply to you.

This warranty gives you specific legal rights and you may also have other rights which vary from state to state.

