

WINEGARD®

Digital Elevation Sensor Electronic Calibrated Model for RM and RD models Model DE-4600/4646

U.S. Patent 5,945,945

**THIS UNIT HAS
BEEN CALIBRATED
AT THE FACTORY.
No further calibration
is necessary.**

(If for some reason, this unit's calibration fails, See Steps 4 through 8 in this manual.)

Before you begin, take a few minutes to look at **Figure 1**. Be sure you have received all parts pertaining to your **specific model**. Contact Winegard Company for help with questions concerning our products.

Customer service hours are 7:30 a.m. to 5:00 p.m., Mon. - Thu., 7:30 a.m. to 4:00 p.m., Fri., Central Time. Call toll-free 1-800-288-8094.

**For RD models, use Steps 1 and 2.
For RM models, use Step 3.**

Step 1. Figure 2. Assemble Sensor to mounting plate using the two (2) #10-32 x 1/2" screws and #10-32 hex nuts, Figure 2.
CAUTION: Over-tightening screws is unnecessary and may cause breakage of case.

Step 2. Figure 3. Positioning antenna to a near vertical angle will make installation easier. Assemble mounting plate against fixed feed arm by removing existing 1/4" nuts, bolts and washers. Using new hex bolts and previously removed nuts and washers assemble parts as shown. Align the plate parallel, Figure 3, to elevating tube and tighten hardware. **Go to Step 9.**

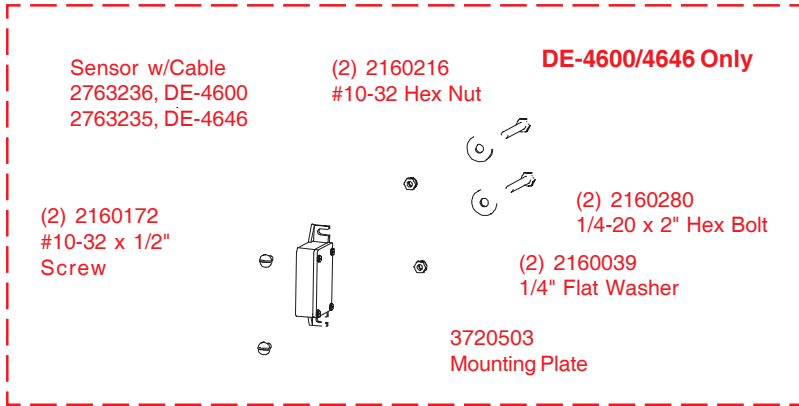

Figure 1

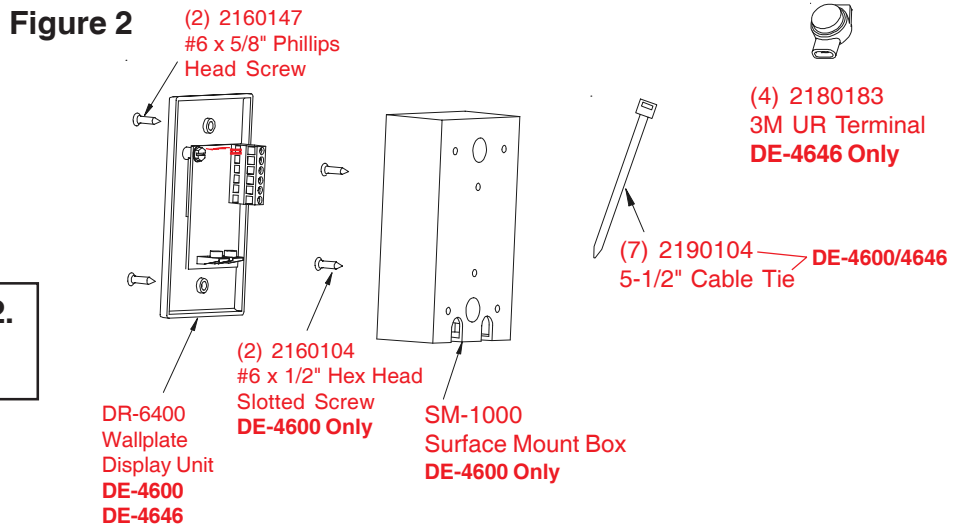
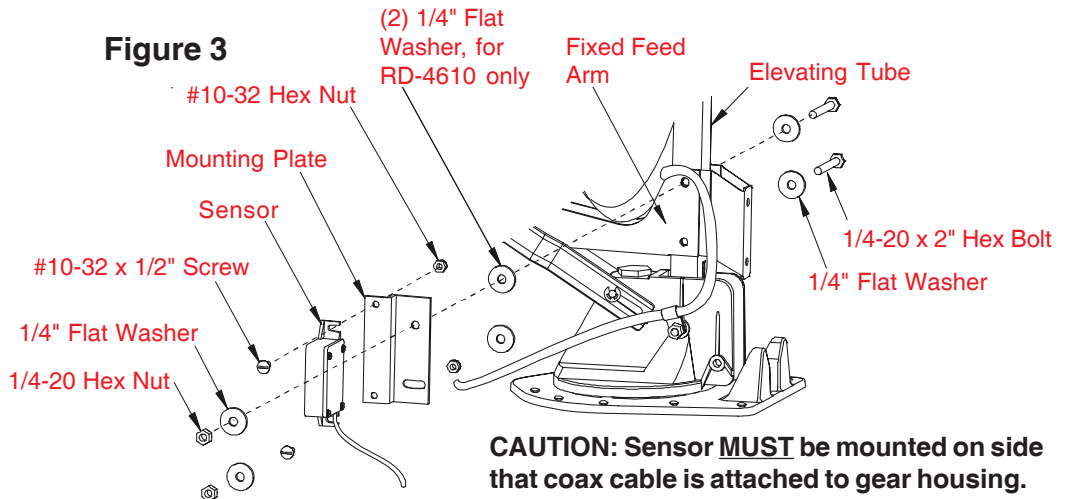

Figure 3



CAUTION: Sensor MUST be mounted on side that coax cable is attached to gear housing. Mounting differently than shown WILL CAUSE IMPROPER OPERATION.

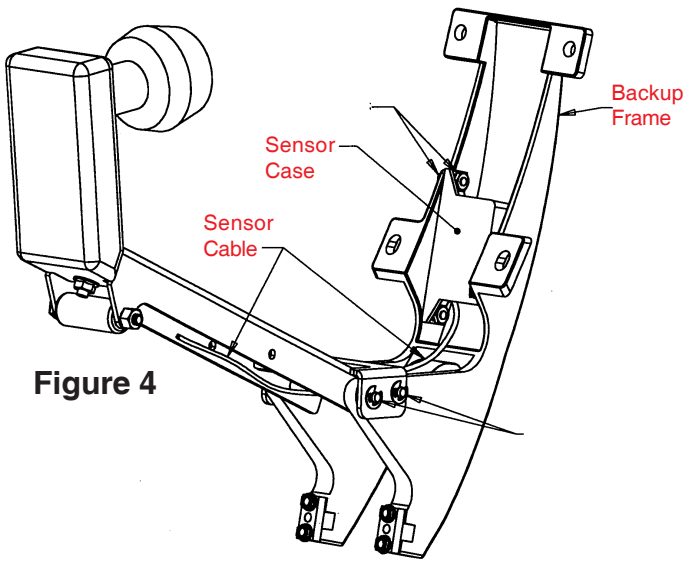

Figure 4

Step 3. Figure 4. To install Sensor with your RM model, remove dish from backup frame. Place Sensor inside backup frame, Figure 4. Cable must exit from bottom of Sensor. Route under pins, refer to Figure 4. Be sure sensor case is placed so mounting screws are completely in slots. Fasten Sensor case to frame, being careful not to overtighten screws. Secure Sensor cable to coax with wire ties. **Go to Step 9.**

If at any time after installation, calibration is necessary, follow Steps 4 through 8.

Step 4. Figure 5. Using cable ties attach sensor cable to coax cable. Some RV manufacturers have prewired their coaches with cable for the digital elevation sensor. You will find these wires at the appropriately marked spot on roof. If not prewired, you need to run wires from sensor through opening (normally same entrance as coax) into coach terminating them where you are installing the wall plate display unit. It is recommended that the display unit be mounted so you can read the elevation numbers while cranking antenna to the correct angle.

Step 5. Figure 5. Two persons will be required for this step. Raise antenna to vertical (plumb) position. Place a level across face of antenna as shown and adjust to a perfect plumb. **BE ACCURATE!**

Step 6. Figure 6 shows the different methods of connecting wires at roof level. Method will depend on model. Wire colors **MUST MATCH**, i.e. red to red.

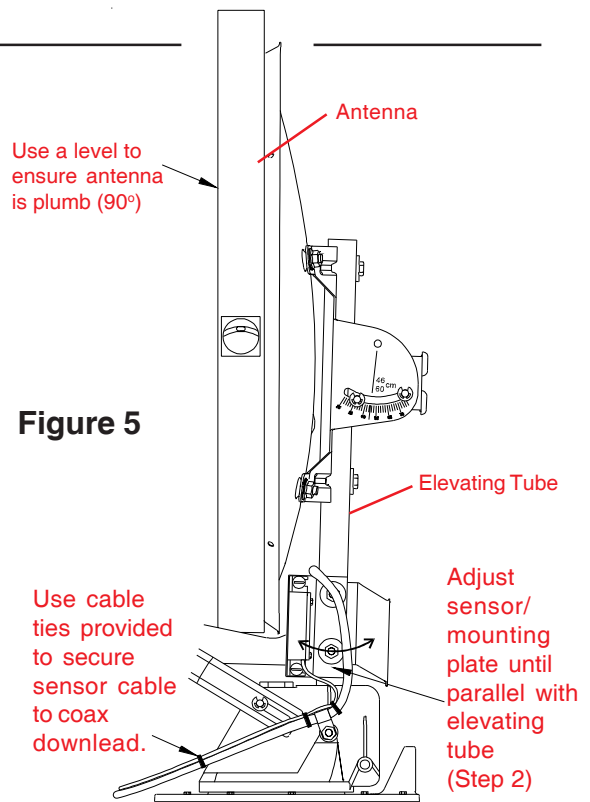

Figure 5

Figure 6

Supplied with the DE-4646 only.

NOTE: This terminal is weatherproof and can be left outside on the roof as LONG AS IT IS SECURED PROPERLY to prevent whipping in the wind.

3M UR Terminal

Slide wires all the way in. **DO NOT strip wires, terminal is self stripping.**

Squeeze pliers until red plunger is flush with rest of terminal.

Pliers not supplied

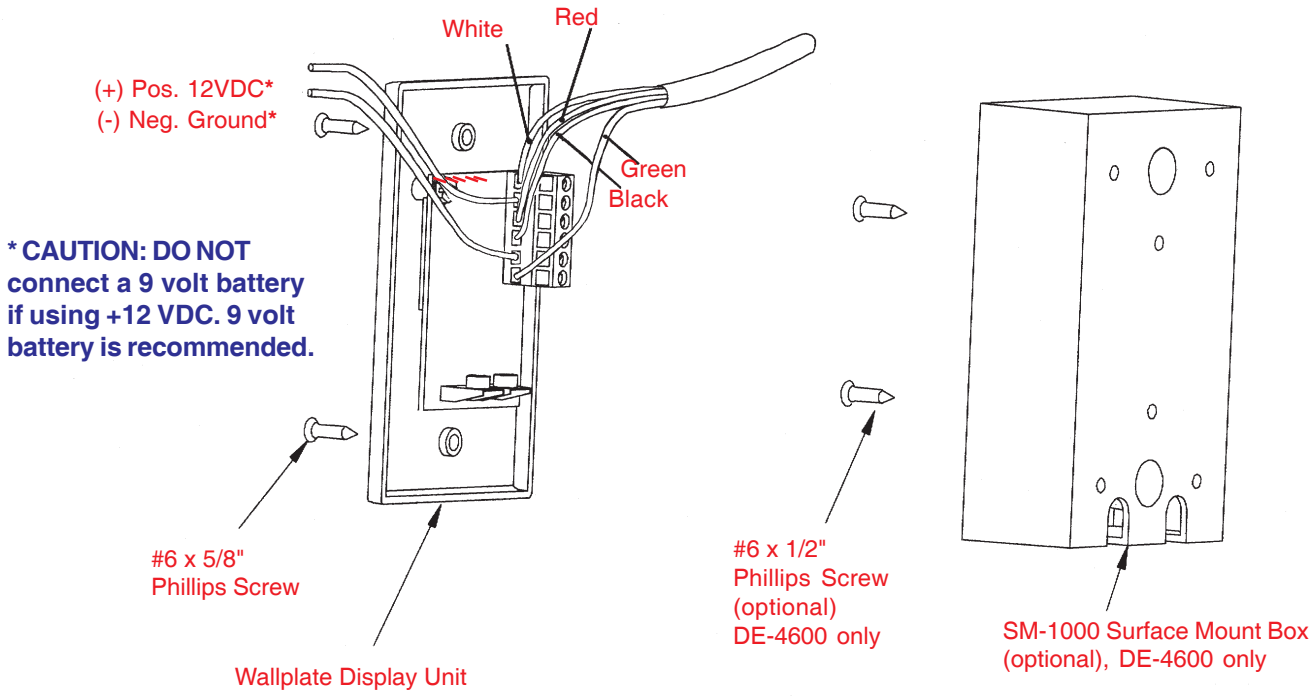

CAUTION: If using +12 VDC, it must be FILTERED!
 If using non-filtered +12 VDC, the product will be **damaged** and **Warranty voided**.

Figure 7

Step 7. Figure 7. If using the SM-1000 surface mount box, feed cable through hole in box. Connect wires coming from sensor on roof to wall plate display in coach. It is required to strip wires 1/4". It is **IMPORTANT** to have connected the wires properly at roof and to connect properly at wall plate. System is designed to use a 9 volt battery (recommended) **OR** +12 VDC from RV (*not both*). When inserting and tightening the wires into terminals on back of display board, be sure that you have clamped on the bare wire conductor and not the insulation. **DO NOT** connect the +12 VDC at this time. **IMPROPER WIRING WILL CAUSE DAMAGE TO THE PRODUCT.**

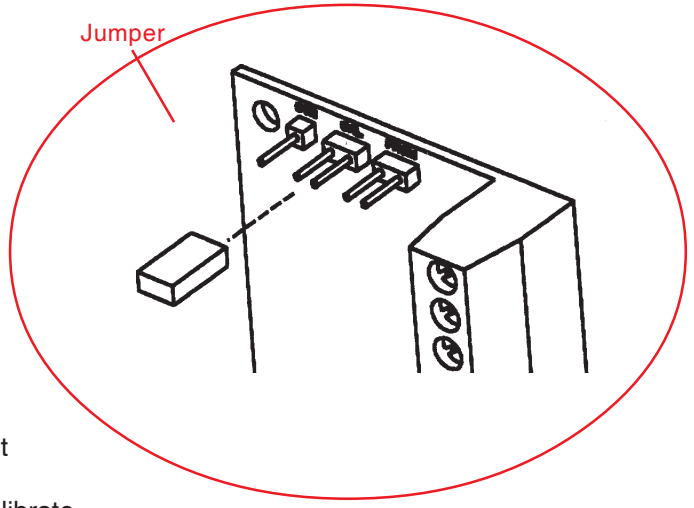

Step 8. Figure 7. There are five pins on back of display circuit board. Place jumper (small plastic plug in the hardware bag) across the second and third pin from the left. These are the calibrate pins. Install a 9 volt battery and press the button on front of display. The readout should display the letters CA (calibration) for approximately 10 seconds. The display will then start alternating between two sets of numbers of no importance to you. At this time remove battery. Now remove jumper and place on the single pin to the left. Electronic calibration is now complete.

WIRING

Step 9. Use the 9 volt battery (**9 volt recommended for best performance**) or hook up the +12 VDC. Pressing the button should display 24 (+ or - 1 degree) when antenna is in vertical position. **Display automatically turns off after approximately 1 minute.**

Step 10. Figure 8. It is recommended if using 9 volt battery, a cable tie be installed to secure the battery. The tie should not be too tight because the battery will need to slide out for replacement.

STEP 11. CHECK CONNECTORS AND CABLE ENTRY POINTS. MAKE SURE THESE AREAS HAVE BEEN PROPERLY SEALED TO PREVENT WATER DAMAGE TO YOUR SYSTEM AND PROPERTY.

Troubleshooting — EE readings on display: Check wiring for poor connection or incorrect wiring.

Figure 8

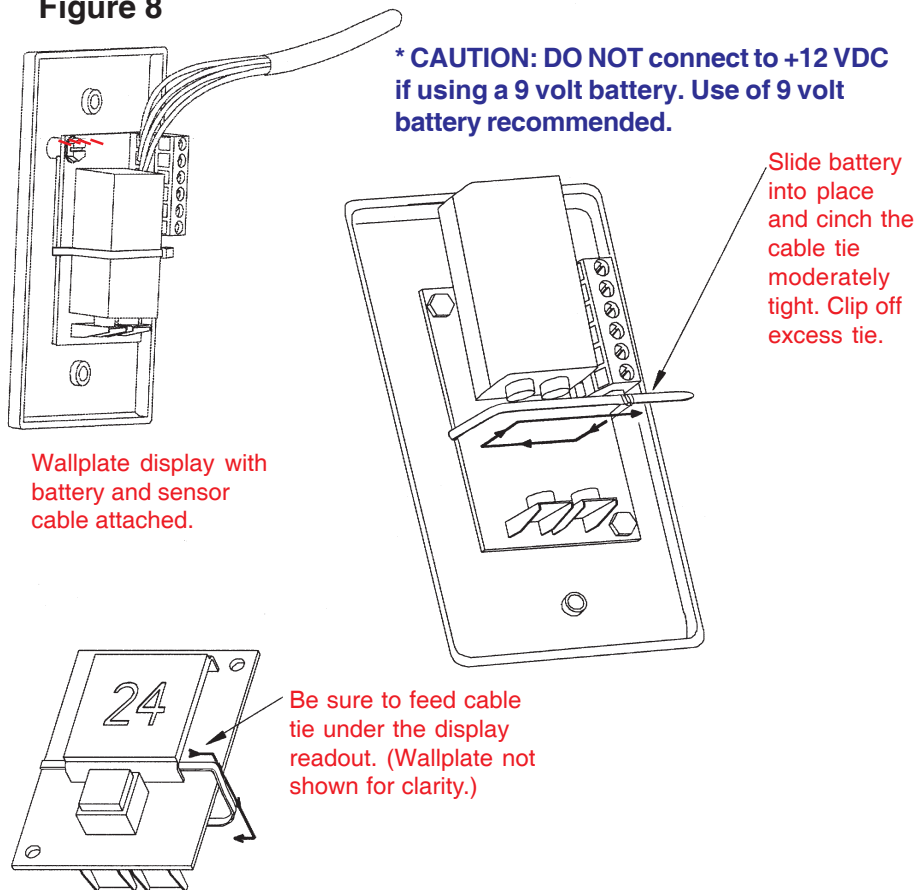

OPERATING INSTRUCTIONS

Step 1. Using satellite receiver, determine correct elevation for your location. See your receiver manual for details on how to obtain setup information.

Step 2. Press button on Winegard Digital Display Wall plate. If antenna is in travel position, the display will show HH for high limit. (LL for low limit.)

Step 3. Crank elevation handle to raise antenna. Stop cranking when readout displays correct elevation for your location. (Found on receiver setup menu.)

Step 4. Rotate antenna **VERY SLOWLY** until correct satellite signal is acquired. NOTE: Rotate 2° and stop. DO NOT rotate continuously even if you are rotating slowly. If you notice elevation angle has changed, it could be due the following reasons:

1. RV is not parked level.
2. Antenna system is mounted to a slightly sloped RV roof. If this is the reason, when you have rotated the antenna so it is facing in the approximate correct azimuth (compass direction), simply adjust to correct elevation and continue searching for signal.

Special Notes: When you have detected the satellite signal adjust the antenna up/down and left/right for strongest signal your receiver displays. Due to variations in receivers and installation methods, you may find the elevation numbers after peaking on strongest signal no longer match what the receiver recommended. This is normal. The elevation sensor should always get you close enough to pick up a signal to peak on. If display turns off while you're searching, just push button for another minute of operation. After a little practice, most people find the signal in 30 to 50 seconds.

Replacement Parts

To order repair parts, contact Winegard Company. **Customer service hours are 7:30 a.m. to 5:00 p.m., Mon. - Thu., 7:30 a.m. to 4:00 p.m., Fri., Central Time. Call toll-free 1-800-288-8094.** Credit card only, \$5.00 minimum order. For parts, refer to page one of this instruction sheet.