

WINEGARD® ROADSTAR™ RV AND VAN TV ANTENNA MODELS RS-2000 & RS-3460/RS3460B

Made in U.S.A.

INSTRUCTIONS

SPECIFICATIONS

| | |
|-----------------------------------|---|
| Bandpass | |
| VHF/FM | 54 to 216 MHz |
| UHF | 470 to 810 MHz |
| Amplifier Gain | |
| VHF* | 15.5 dB avg. |
| UHF | 19.5 dB avg. |
| Impedance | 75 ohm unbalanced |
| Response | 25 dB per 6 MHz |
| VSWR | 1.8:1 max. |
| Power Required | 12 VDC at 85 ma |
| Weatherproof Housing | Weatherable UV stabilized copolymer |

*Has fixed FM trap to reduce interference.

DESCRIPTION

Winegard's RoadStar™ omnidirectional antenna provides excellent reception of VHF/UHF TV channels. The RoadStar compact modern styling is unobtrusive and blends well with the designs of recreational vehicles. The UV stabilized copolymer housing makes the antenna virtually impervious to weathering and color change.

The unique omnidirectional characteristics provide excellent reception in areas where stations are in different directions without the need for a complex rotor system. A built-in amplifier provides up to 6 times the received signal on VHF and 9 times the UHF signal insuring the best possible reception in color and black and white.

The RS-2000 package includes antenna, 12 VDC power supply with two-way splitter, 30' download cable, 6' TV set cord, hardware and mounting bracket.

PARTS LIST (RS-2000) White Housing

| | | |
|---|--------------------------------|---------|
| 1 | Amplified Antenna | 2120415 |
| 6 | 10-32 Hex Nut, Nylock | 2160216 |
| 1 | Power Supply with Hardware | 2120123 |
| 1 | 30' Coaxial Cable | 2753015 |
| 1 | 6' Coaxial Cable | 2753752 |
| 3 | Roof Mounting Brackets | 3720303 |
| 6 | #10 x 1" Thread Cutting Screws | 2160178 |
| 1 | Bolt, 1-14 x 1" Nylon | 3200350 |
| 1 | Mounting Plate | 3710248 |
| 6 | 10-32 x 5/8" Bolt | 2160173 |
| 6 | Washer, #10 Aluminum | 1140302 |

PARTS LIST (RS-3460) White Housing (RS3460B) Black Housing

| | | |
|---|--------------------------------|---------|
| 1 | Amplified Antenna (white) | 2120415 |
| | Amplified Antenna (black) | 2120404 |
| 6 | 10-32 Hex Nut, Nylock | 2160216 |
| 3 | Roof Mounting Brackets | 3720303 |
| 6 | #10 x 1" Thread Cutting Screws | 2160178 |
| 1 | Bolt, 1-14 x 1" Nylon | 3200350 |
| 1 | Mounting Plate | 3710248 |
| 1 | Coaxial Cable Boot | 3200154 |
| 6 | 10-32 x 5/8" Bolt | 2160173 |
| 6 | Washer, #10 Aluminum | 1140302 |

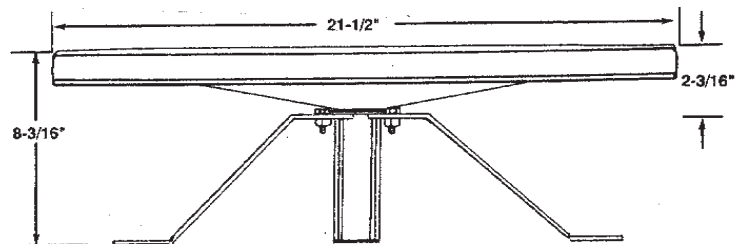

CLEANING ANTENNA HOUSING

The surface of the antenna is a tough laminated ultraviolet shield. Clean only with mild soap and water. **Use no solvents, alcohol, or cleaning fluids.**

Winegard Company
3000 Kirkwood St., Burlington, IA 52601-2000

Printed in U.S.A. 2451806 © Winegard Company, 1998, 2004, 2006 Rev. 2/08

ANTENNA MOUNTING INSTRUCTIONS

STEP 1. Assemble mounting brackets onto mounting plate. Insert 10-32 x 5/8" bolts through mounting plate and mounting brackets. See Figure 1. Attach #10 x 9/16 x 1/6 washers and 10-32 locking nuts. Tighten securely.

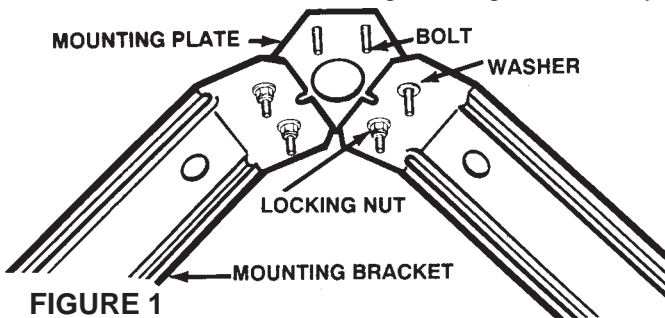

FIGURE 1

STEP 2. Place assembled mount on bottom of antenna housing and thread in 1" nylon bolt. Spin the assembled mount to tighten securely.

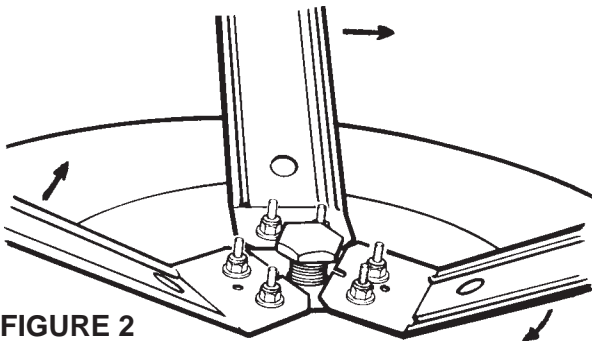

FIGURE 2

STEP 3. Attach end of coaxial download cable with boot to jack on bottom of antenna and slide boot up over boot collar. See Figure 3.

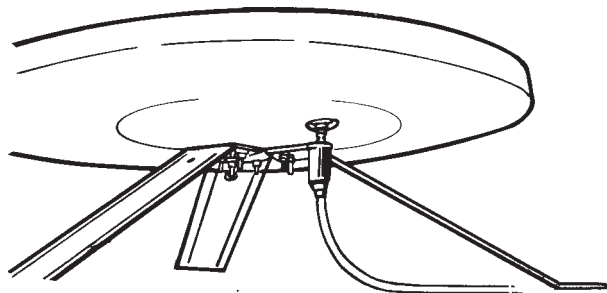

FIGURE 3

STEP 4. Select location for antenna on roof of vehicle. Try to position antenna about 24" from edge of vehicle roof, convenient to download entry point and as far away as possible from roof mounted equipment such as air conditioners or roof vents. See Figure 4.

Note: Locating antenna close to air conditioning unit or roof vents over 8" high may cause poor picture quality and snow.



FIGURE 4

NOTE: Holes for mounting brackets are at corners of 19-5/8" triangle. We recommend you make a template from 19-5/8" triangular piece of cardboard. Try to locate holes on roof rafters on other solid members inside roof. See Figure 5.

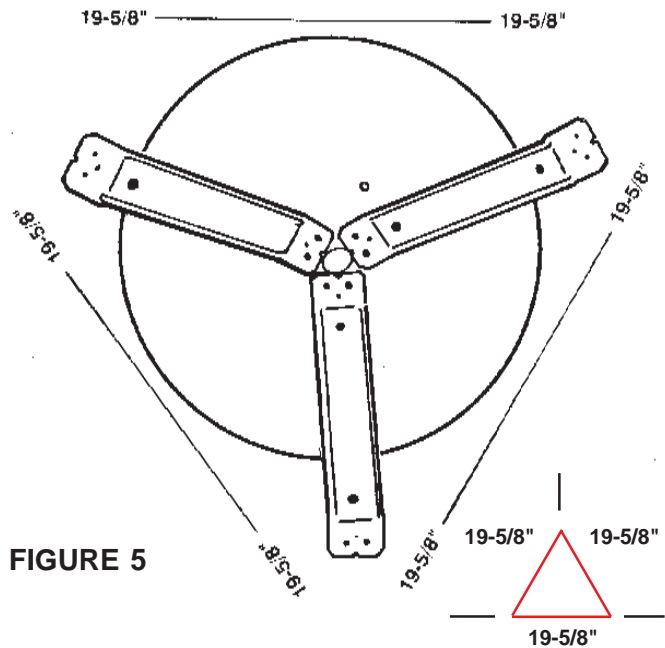

FIGURE 5

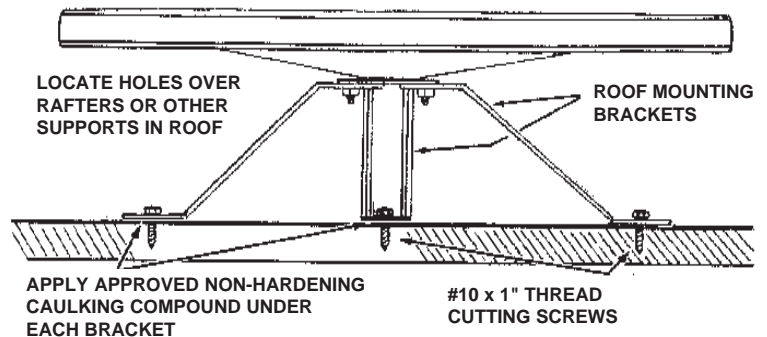

FIGURE 6

STEP 5. Drill six 1/8" pilot holes as shown in Figure 6. Apply approved sealant for your type of roof around holes under each bracket. Attach antenna to roof with #10 x 1" thread cutting screws.

STEP 6. The power supply/wall outlet assembly may be flush mounted in most standard electrical boxes. To flush mount cut a hole in wall to fit the box. Run 2 #12 wires between wall outlet and 12VDC source and route download cable to this location. Install cable between set 2 outlet and power supply SET 2 jack at this time. See Figure 7.

WARNING: DO NOT CONNECT 12 VDC SOURCE TO POWER SUPPLY AT THIS TIME. POWER SUPPLY MAY SHORT, IF 12 VDC SOURCE IS CONNECTED.

STEP 7. Install connectors on download and set 2 cable as shown on page 4. Attach antenna download cable to jack on power supply marked "ANT". See Figure 7.

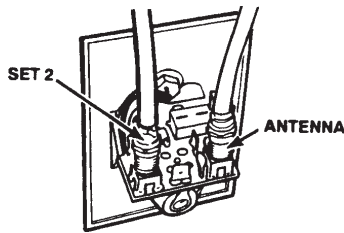

FIGURE 7

STEP 8. Install terminals on wires from 12 VDC source as shown in Fig. 8. Crimp terminals with Craftsman type 4 crimping tool in Fig. 9 or equivalent. Push wires onto tabs on terminal board as shown in Figure 10. If in doubt as to the polarity of the wires, connect them temporarily to tabs on circuit board in Fig. 10 and move switch on front of outlet to left, (in Fig. 11) if light comes on polarity is correct.

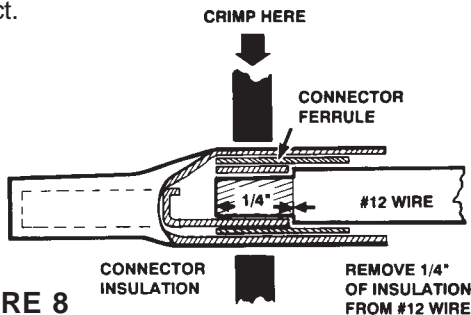

FIGURE 8

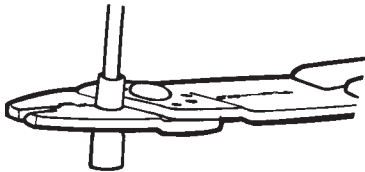

FIGURE 9

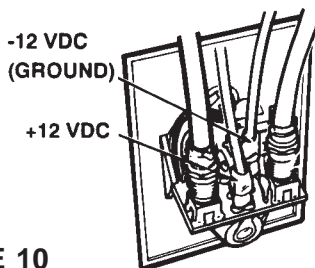

FIGURE 10

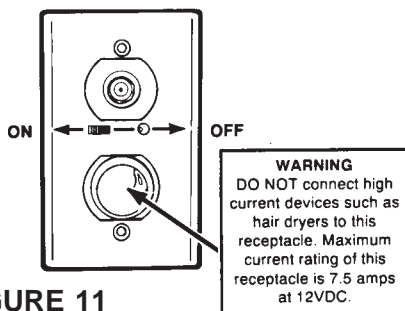

FIGURE 11

STEP 9. Mount power supply in wall with screws provided and attach TV coax cable to jack on front. Connect TV coax cable to TV set. Move switch on front of outlet to the left and check that light is on.

CHECKING POWER SUPPLY OPERATION

(Power Supply not supplied with RS-3460)

1. Tune TV receiver to nearest station.
2. Turn off switch on power supply. Picture on TV receiver should be considerably degraded with power off.
3. **This unit is equipped with a polyswitch**, (current limiting device), which will shut down 12 VDC if there is a direct short in the cable between antenna and power supply. Red indicator light will not light. Once short is eliminated, device will reset itself.

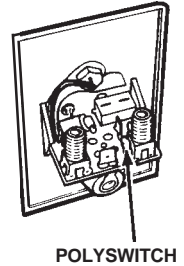

POLYSWITCH

WINEGARD MOBILE PRODUCTS LIMITED WARRANTY (2 YEARS PARTS; 1 YEAR LABOR)

Winegard Company warrants this product against defects in materials or workmanship for a period of two (2) years from the date of original purchase. During year one (1) of such warranty, Winegard Company will also pay authorized labor costs to an authorized Winegard dealer to repair or replace defective products. No warranty claim will be honored unless at the time the claim is made, Customer presents proof of purchase to an authorized Winegard dealer (to locate the nearest authorized Winegard dealer, contact Winegard Company, 3000 Kirkwood Street, Burlington, Iowa 52601, Telephone 800-288-8094 or visit www.winegard.com). Customer must provide proof of purchase with a dated sales receipt for the Winegard product to verify the product is under warranty. If the date of purchase cannot be verified, the warranty period shall be considered to begin thirty (30) days after the date of manufacture.

If a defect in material or workmanship is discovered, Customer may take the product to an authorized Winegard dealer for service. Customer must provide proof of purchase to verify the product is under warranty. If the product is brought to an authorized Winegard dealer for service prior to expiration of year one (1) of the warranty period and a defect in material or workmanship is verified by Winegard Technical Services, Winegard Company will cover the Winegard dealer's labor charges for warranty service. The Winegard dealer must contact Winegard Technical Services in advance for pre-approval of the service. Approval of the service is at the sole discretion of Winegard Company.

Alternatively, Customer may ship the product prepaid to Winegard Technical Services (located at 3111 Kirkwood Street, Burlington, Iowa 52601, Telephone 800-788-4417). Customer must return the product along with a brief description of the problem and provide Winegard Technical Services with Customer's name, address, and phone number. Customer must also provide proof of purchase to verify the product is under warranty. If the product is returned before the expiration of the warranty period, Winegard Company will (at its option) either repair or replace the product.

This Limited Warranty does not apply if the product has been damaged, deteriorates, malfunctions or fails from: improper installation, misuse, abuse, neglect, accident, tampering, modification of the product as originally manufactured by Winegard in any manner whatsoever, removing or defacing any serial number, usage not in accordance with product instructions or acts of nature such as damage caused by wind, lightning, ice or corrosive environments such as salt spray and acid rain.

RETURN AUTHORIZATION POLICY

A Return Material Authorization (RMA) is required prior to returning any product to Winegard Company or Winegard Warranty Services under this warranty policy. Please call our Technical Services Department at 800-788-4417 or send an e-mail to warranty@winegard.com to obtain the RMA number. Please furnish the date of purchase when requesting an RMA number. Enclose the product in a prepaid package and write the RMA number in large, clear letters on the outside of the package. To avoid confusion or misunderstanding, a shipment(s) without an RMA number(s) or an unauthorized return(s) will be refused and returned to Customer freight collect.

WINEGARD COMPANY DOES NOT ASSUME ANY LIABILITIES FOR ANY OTHER WARRANTIES, EXPRESS OR IMPLIED, MADE BY ANY OTHER PERSON.

ALL OTHER WARRANTIES WHETHER EXPRESS, IMPLIED OR STATUTORY INCLUDING WARRANTIES OF FITNESS FOR A PARTICULAR PURPOSE AND MERCHANTABILITY ARE LIMITED TO THE TWO YEAR PERIOD OF THIS WARRANTY.

In states that do not allow limitations on implied warranties, or the exclusion of limitation of incidental or consequential damages, the above limitations or exclusions do not apply.

Some states do not allow limitations on how long an implied warranty lasts, or the exclusion of limitation of incidental or consequential damages, so the above limitations or exclusions may not apply to you.

This warranty gives Customer specific legal rights. Customer may also have other rights that may vary from state to state.

SATELLITE RECEIVER WARRANTY:

See manufacturer's limited warranty policy.

WHAT TO DO WHEN YOUR RV/TV ANTENNA IS NOT WORKING PROPERLY

INSTALLING COAX CABLE ON FC- 5910 CONNECTORS

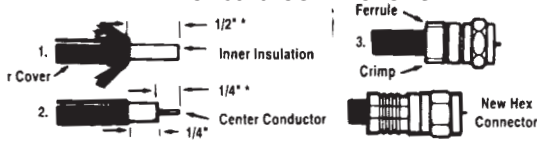

STEP 1: Strip outer cover back 1/2" from end of cable. Fray braid back as far as outer cover will allow.

STEP 2: Trim braid close to outer cover and remove 1/4" of inner insulation **being careful not to nick center conductor**. Make sure no foil or braid can touch center conductor.

STEP 3: Slide connector tip between braid and inner insulation (braid and foil, on foil shield cable) and push connector on cable as far as it will go. Crimp built-in ferrule with appropriate crimping tool. **Do Not crush cable out-of-round.** *If installing in very hot weather, increase these dimensions 1/8".

* If installing in very hot weather, increase these dimensions 1/8".

WARNING

DO NOT INSTALL COUPLERS, SPLITTERS, ETC. BETWEEN THE POWER SUPPLY AND THE ANTENNA. INSTALLATION OF ANY ITEM ON THE DOWN-LEAD MAY CAUSE A SHORT IN THE SYSTEM. THE DOWNLEAD SUPPLIES +12 VDC TO THE PREAMP IN THE ANTENNA.

HOW YOUR SYSTEM WORKS

Turning power supply on sends +12 VDC up cable to antenna. Voltage energizes transistors on amplifier in antenna head. TV signal comes back down cable to outlets.

TO TEST SYSTEM

1. Make sure TV set is working properly.
2. Switch power supply ON and OFF to see if there is a difference in the picture quality while watching TV. If there is NO difference, proceed to the next step.

CAUTION

The power supply should be turned OFF when connecting/disconnecting cables to power supply and antenna, but should be turned ON when testing for voltage.

3. Disconnect cable from antenna and check for +12 VDC at test point #1. If there is +12 VDC, the power supply is OK and the antenna needs to be replaced.

4. If there is no +12 VDC at test point #1 reconnect the cable to antenna. Remove power supply from wall and visually inspect for burnt/broken parts. If there are any broken or burnt parts replace power supply.

5. Disconnect cable from antenna jack on power supply. Check for +12 VDC at test point #2. If there is +12 VDC then there is a problem in the cable connecting the power supply to the antenna. Repair/ replace cable.

6. If +12 VDC is not present at test point #2, check that the red indicator is ON. If not, check the polarity of the red/ white wires and check the +12 VDC source. If there is still no +12 VDC replace the power supply.

HOW YOUR SYSTEM WORKS

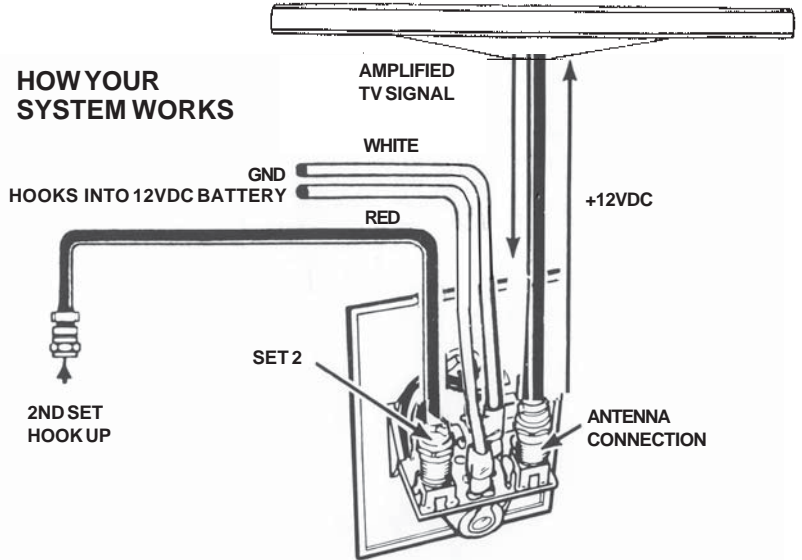

TEST POINT #1 +12VDC AT ANTENNA

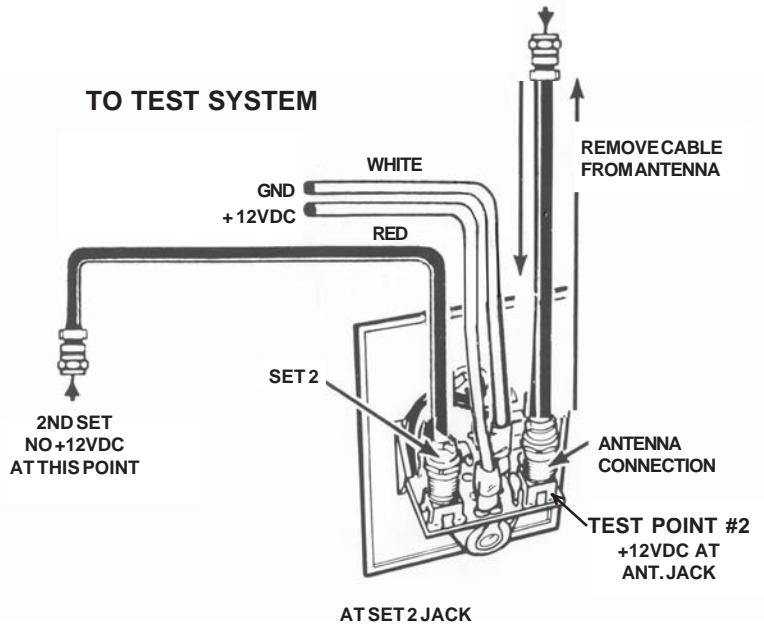
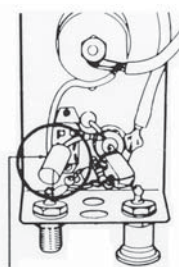
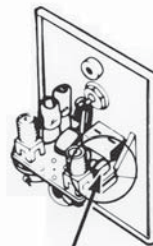

FIGURE 1



RF CHOKE
POWER SUPPLY
IN METAL HOUSING

FIGURE 2



RF CHOKE
POWER SUPPLY
NO POLYSWITCH

FIGURE 3

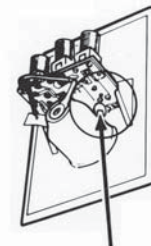

POLYSWITCH
POWER SUPPLY
W/POLYSWITCH

FIGURE 4



POLYSWITCH
POWER SUPPLY
W/POLYSWITCH