

OWNER'S MANUAL - OPERATION/INSTALLATION INSTRUCTIONS

# WINEGARD®

## RV Digital Satellite System with RS-1000 Antenna

Model RM-4610, no Digital Magic™ Elevation Sensor  
Model RM-DM61 with Digital Magic™ Elevation Sensor  
Model RM-DM55 with Digital Magic™ (No Power Supply)

Made in U.S.A.

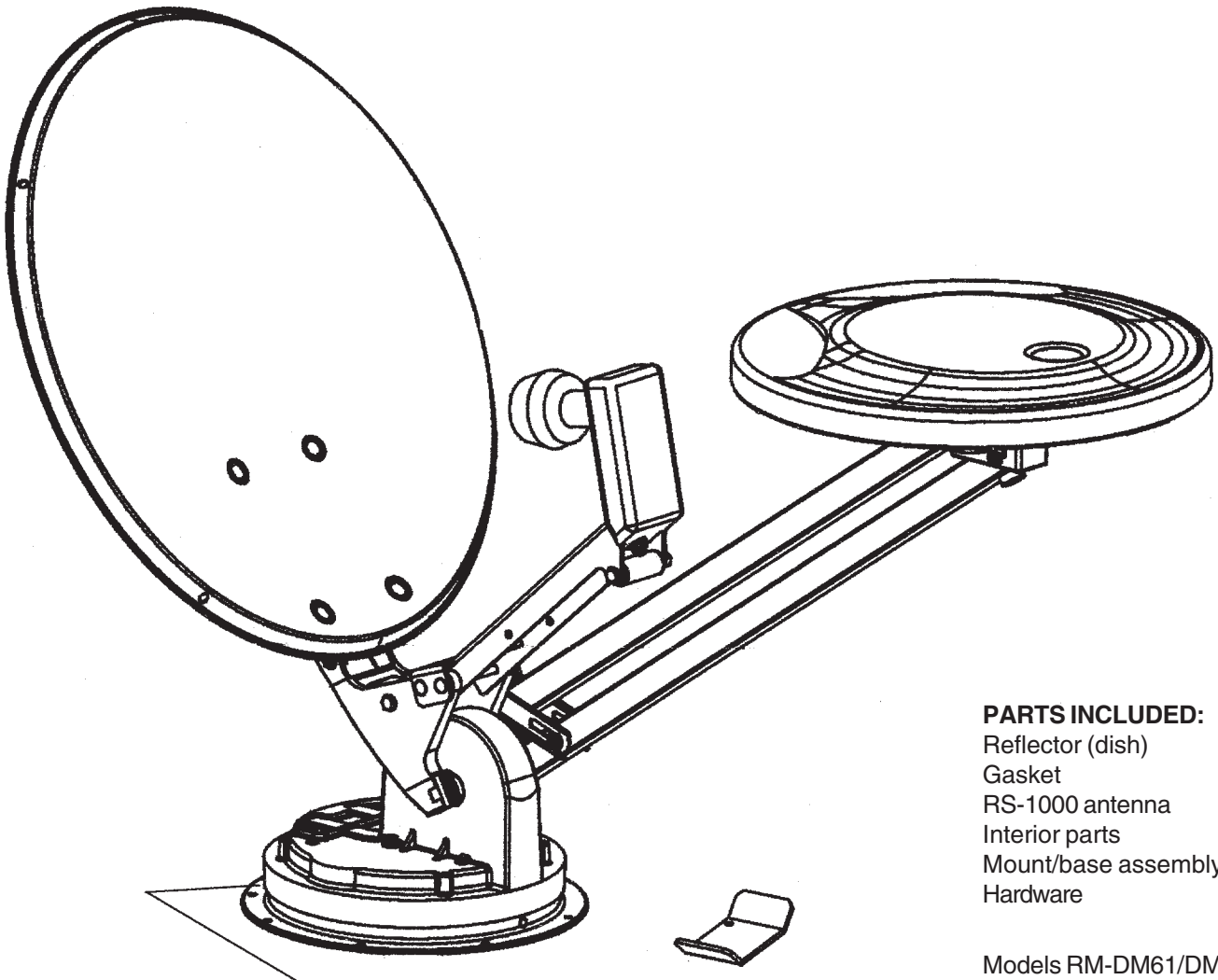

**INSTALL "FRONT" INSCRIBED  
ON BASE TOWARD FRONT  
OF VEHICLE!**

**PARTS INCLUDED:**

Reflector (dish)  
Gasket  
RS-1000 antenna  
Interior parts  
Mount/base assembly  
Hardware

Models RM-DM61/DM55  
Electronic elevation sensor

Models RM-4610/DM61  
Power supply

## FINDING THE SATELLITE

**STEP 1.** Step outside the vehicle and, using a compass, determine which direction is North. (Standing in or near the vehicle can give you an incorrect reading.) The more accurately you determine North, the easier it will be to find the satellite(s).

**STEP 2.** Using satellite receiver, determine correct elevation for your location. See your receiver manual for setup information.

**STEP 3.** Press button on Winegard Digital Display wall plate. If the antenna is in travel position, the display will show LL for Low Limit. HL for High Limit will show when dish is in Up position.

**STEP 4.** Crank elevation handle to raise antenna. Stop cranking when readout displays the correct elevation for your location.

**STEP 5.** Rotate antenna **VERY SLOWLY** until correct satellite signal is acquired. NOTE: Rotate 3° and then stop. DO NOT rotate continuously, even if you are rotating slowly. If you notice the elevation angle has changed, it may be due to the following reasons:

- a. RV is not parked level.
- b. Antenna system is mounted to a slightly sloped RV roof. (This is not a problem. **When you have rotated the antenna so it is facing in approximately the right azimuth [compass direction], simply adjust to correct elevation and continue searching for the satellite signal.**)

**Special notes:** When you have detected the satellite signal, adjust the antenna up/down and left/right for the strongest signal your receiver displays. Because of differences in receivers and installation methods, you may find the elevation numbers, after peaking on the strongest signal, no longer match what the receiver recommended. This is normal. The elevation sensor should always get you close enough to find a signal to peak on. If display turns off while you're searching, just push button for another minute of operation. After a little practice, most people can find the signal in 30 to 50 seconds.

## TROUBLESHOOTING

- If digital display reads EE, check wiring and connection. If wiring and connections are not correct at installation, operation is affected.
- Remember to rotate antenna **VERY SLOWLY** until correct satellite signal is acquired.

## DISPLAY CODES

HL ..... High Limit  
LL ..... Low Limit  
Lo ..... Battery Low  
Er ..... Communication Error  
— — ..... Initializing

**NOTE: Initialization may take up to 5 seconds.**

**Based on 5 minutes a day of usage, standard new alkaline batteries should last 88 days.**

## OPERATION

### TUNING ANTENNA FOR THE BEST PICTURE

**STEP 1.** Your receiver should indicate it is receiving a signal. To tune your antenna, **slowly** move the antenna left, then right, until you find the position with the highest signal strength. **It is important to turn the antenna slowly. Because the signal is digital, it takes a few seconds for the receiver to lock on.**

**STEP 2.** Place rotation clamp in the **LOCK** position. This prevents the antenna from moving and losing signal.

**STEP 3.** **Slowly** raise, then lower the antenna until you have "peaked" the signal (found the strongest signal).

ELEVATION	TURNS CW
14 - 16°	14
17 - 19°	14-1/2
20 - 22°	15
23 - 25°	15-1/2
26 - 29°	16
30 - 32°	16-1/2
33 - 35°	17
36 - 38°	17-1/2
39 - 42°	18
43 - 45°	18-1/2
46 - 48°	19
49 - 51°	19-1/2
52 - 54°	20
55 - 57°	20-1/2
58 - 61°	21
62 - 64°	21-1/2
65 - 67°	22
68 - 70°	22-1/2
71-73°	23

### WATCHING OFF-AIR TV

To watch the area (local) television programming, use one of these options —

- Use an A-B switch between the receiver and antenna power supply.
- Use a video switch, Figure 1.
- Connect antenna output from power supply to TV ANTENNA input on receiver, Figure 2. When you turn off the receiver, it automatically switches you to off-air.

### LOWERING ANTENNA TO TRAVEL POSITION

**STEP 1.** Set rotation clamp to ROTATE position.

**STEP 2.** Fully rotate antenna counterclockwise until pointer on directional handle aligns with red screw on rotation clamp.

**STEP 3.** Turn elevating crank counterclockwise **in direction of "DOWN" arrow** until resistance is met. The number of turns will vary according to the elevation angle the antenna was set to.

**STEP 4.** Move rotation clamp to the LOCK position.

**CAUTION: Under no circumstances lower the antenna to any position other than travel position!**

# OPERATIONS DO'S AND DON'T'S

## DO'S

1. Do check parking location for obstructions before raising antenna.
2. Do carefully raise, lower and rotate the antenna — if difficult, check for cause.
3. Do rotate slowly when searching for the satellite(s) and check fine tuning on TV set for proper adjustment.
4. **Do lower antenna before moving vehicle.**
5. Activate programming by calling programming provider for your receiver.

## DON'T'S

1. **Don't move RV/Coach with the antenna in the UP position. This will VOID your warranty. This may also cause damage to your roof.**
2. Don't force the elevating crank up or down. Check for the cause.
3. Don't rotate directional handle hard against stops.
4. Don't apply paint on top of base plate or anywhere on the lift.
5. Don't apply approved sealing compound on gear housing.

### SUGGESTED SETUPS FOR MULTIPLE TVS

FIGURE 1

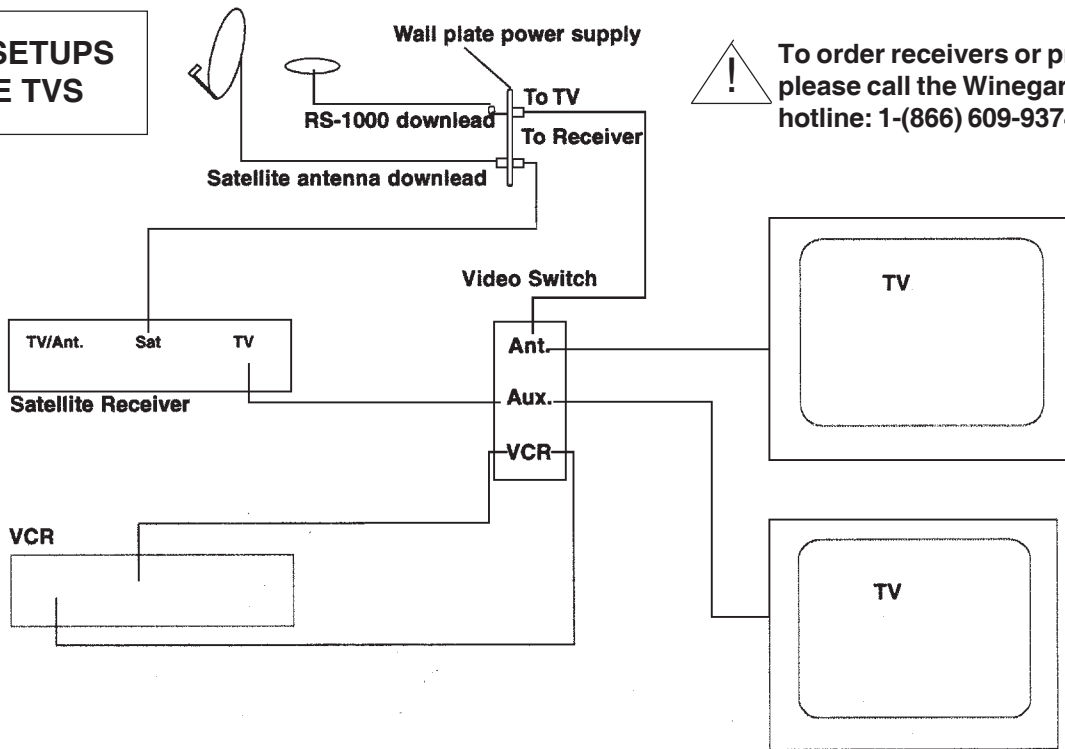
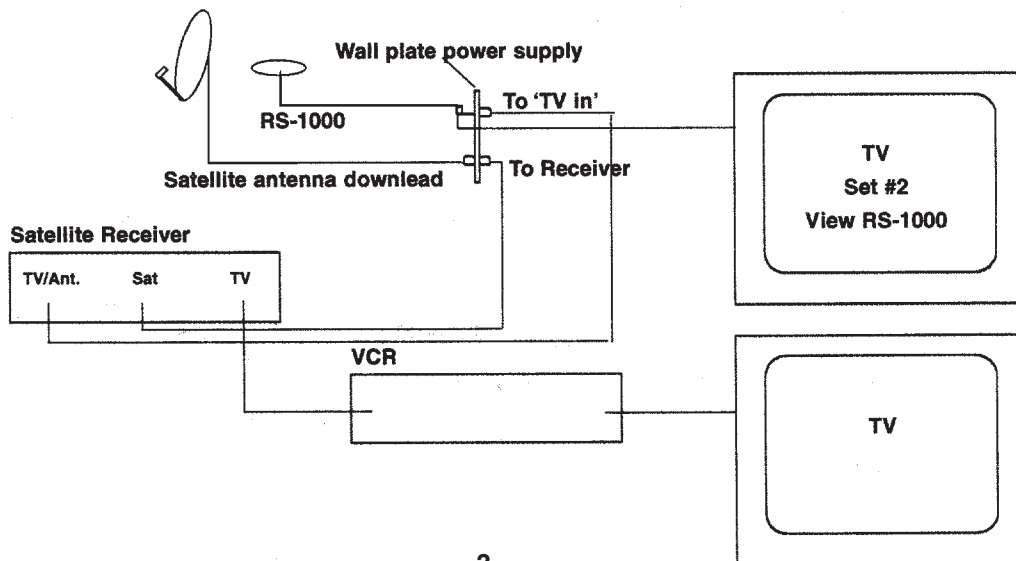

FIGURE 2



## **TROUBLE SHOOTING**

### **NO PICTURE ON TV**

1. Do you have a clear line of sight to the satellite? Are there trees, buildings, etc. in the way? Figure 3 illustrates the look angle of your reflector.
2. Do you have the menu from the receiver? If not, check the channel the TV set is tuned for — it should be 3 or 4.
3. Check connections at the receiver, TV and antenna.

### **NO SIGNAL FOUND**

1. Have you entered the correct zip code into the receiver? If the zip code is wrong, you may be searching in the wrong direction or elevation for the satellite.
2. Is your TV working properly? Does it receive pictures from off-air stations or your VCR?
3. Re-tune system for the best picture, using procedure on page 2.
4. Inspect antenna. Has it been damaged? If it is even slightly bent, the receiver may not receive signal.
5. Do you have +12 VDC at the end of the LNB cable? Remove cable from LNB before testing.
6. Contact your dealer or Winegard Technical Services at 800/788-4417.

### **ANTENNA IS HARD TO ROTATE, OR ANTENNA DOES NOT ROTATE**

1. Inspect antenna on roof. Make sure mount has not been damaged.
2. Be sure there is no sealant between gear housing and base plate.
4. Be sure cable is routed correctly. Cable may be preventing rotation of antenna.
3. Contact your dealer or Winegard Technical Services at 800/788-4417.

### **ANTENNAS HARD TO RAISE, OR ANTENNA DOES NOT RAISE**

1. Inspect antenna on roof. Be sure the mount has not been damaged.
2. Is the antenna obstructed?
3. Contact your dealer or Winegard Technical Services at 800/788-4417.

**FIGURE 3**

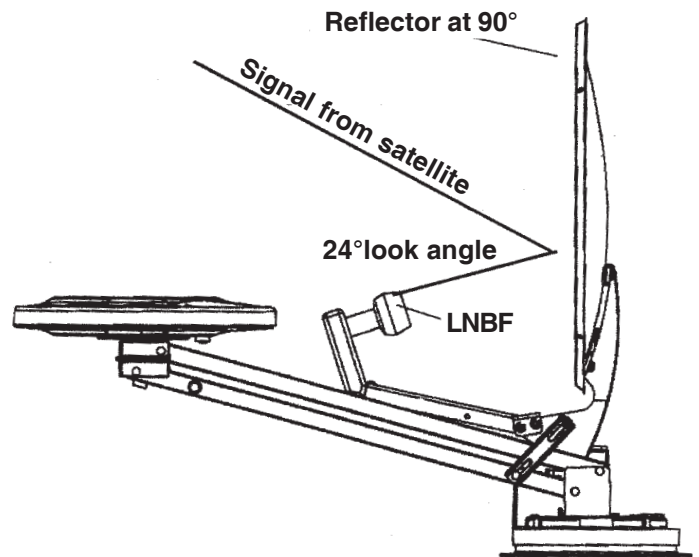

### **WARRANTY REPAIR WORK**

Before you have warranty repairs on your system, be sure the company or individual doing the work has been approved by Winegard Company. If there is not an approved repair company/individual available, contact Winegard Company at 800/288-8094 before proceeding. The Winegard Warranty covers only the mount, antenna and LNB. **For receiver warranty, refer to the receiver manufacturer's warranty.**

### **ORDERING REPAIR PARTS**

Repair parts are available at RV dealers and/or service centers throughout the U.S. Or you can call Winegard Company at 800/288-8094. Credit card orders only, minimum order \$5.00.

# INSTALLATION AND ASSEMBLY

## THINGS YOU NEED

Screwdrivers (Phillips and slot)  
 1-3/4" hole saw  
 7/16" wrench

Drill with 1/8" bit  
 Tape measure

Sealant  
 (Must be approved for compatibility w/roof)

**STEP 1.** Choose a location on the roof for the unit. The dish must be able to rotate without interfering with other roof-mounted equipment (air conditioners, etc.), Figure 4. Be sure the interior ceiling plate is easily accessible with no obstructions that may interfere with operation.

**NOTE:** Check with your dealer or vehicle manufacturer for features that may have been installed for antenna mounting — reinforced roof areas or pre-wire installation done at the factory.

**THE SYSTEM MUST BE LEVEL FOR PROPER OPERATION!** Winegard's RW-5000 roof wedge is available for sloped roofs, Figure 5. If using roof wedge, installer will provide longer mounting screws. **Mount base plate and ceiling plate must be parallel with each other, Figure 5.** If shims or wedges are used, the installer must supply.

**STEP 2.** Position roof template (inserted in this manual) on the roof. **CAUTION: DO NOT drill through wiring.** Carefully drill a 1-3/4" hole through roof and ceiling of vehicle. **Inspect hole to make sure wiring is intact.**

**FIGURE 5**

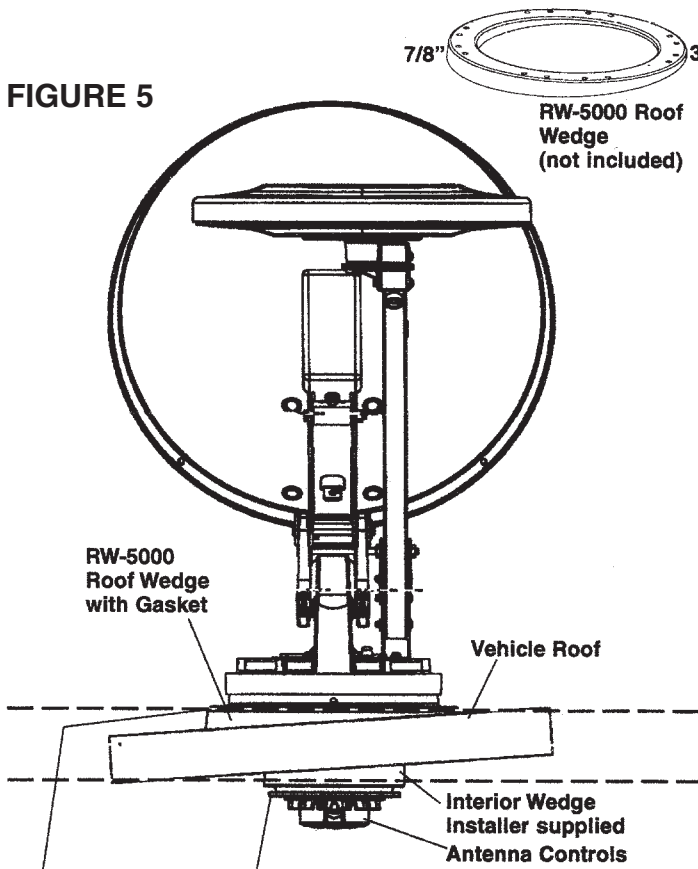

Mount base plate and ceiling plate must be parallel with each other. If shims or wedges are needed, installer must supply.

**FIGURE 4**

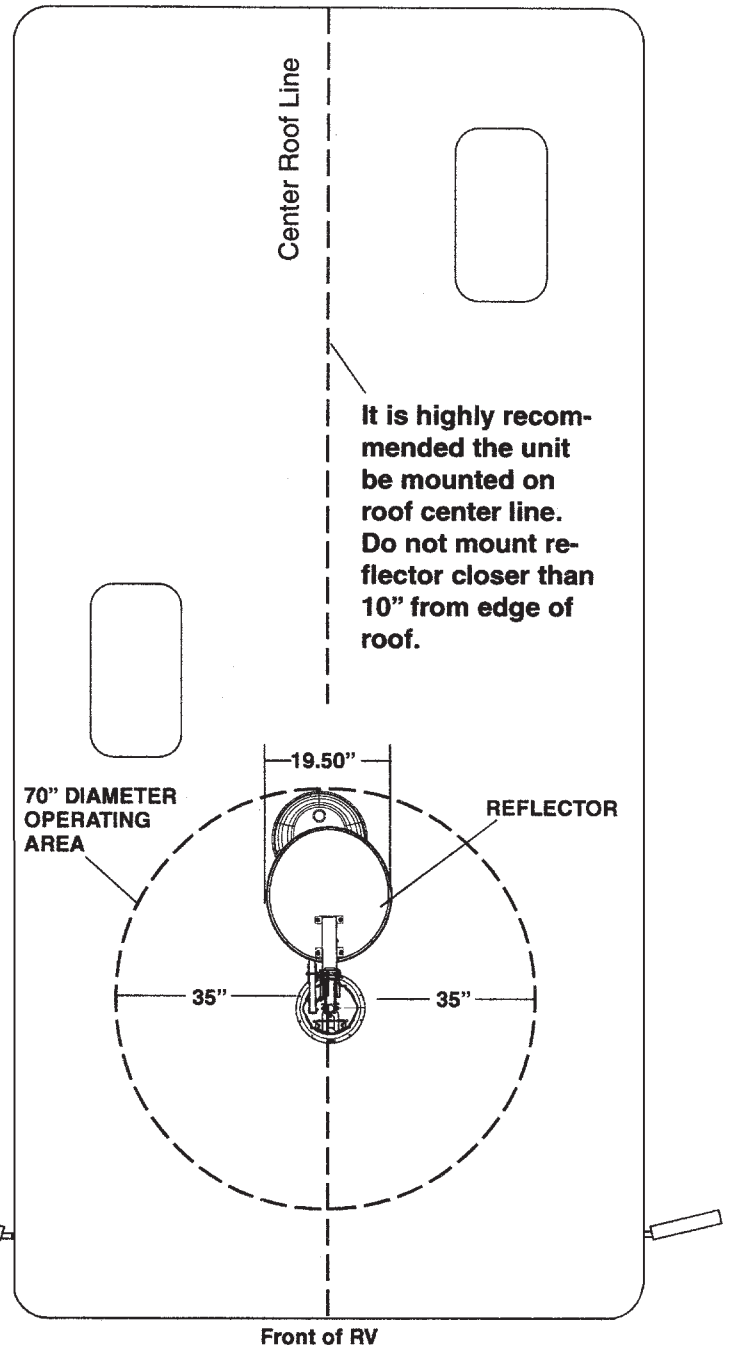

**STEP 3.** Remove backing from gasket. Attach adhesive side to base plate. **IF YOU ARE USING THE ROOF WEDGE (RW-5000),** use 3/16" gasket included with the mount **UNDER** the roof wedge. Install the 1/16" gasket included with RW-5000 **BETWEEN** the mount and roof wedge. See Figure 7.

**The word FRONT is embossed on the base. This MUST FACE the front of the vehicle.**

Secure to roof using two mounting screws provided. Check inside the vehicle. Be sure the shaft is centered in the hole. Attach crank handle to shaft. Crank unit up until it stops.

**FIGURE 6**

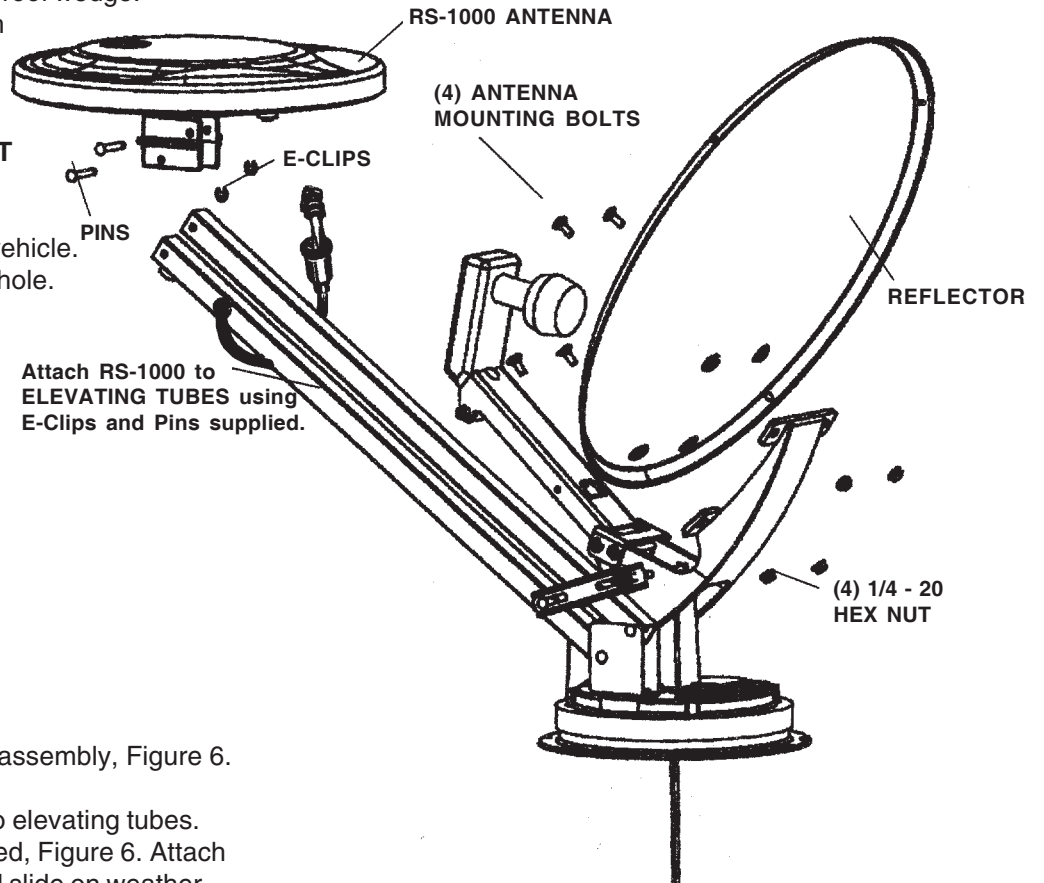

**STEP 4.** Attach reflector to backup assembly, Figure 6.

**STEP 5.** Attach RS-1000 antenna to elevating tubes. Use the two E-clips and pins provided, Figure 6. Attach coax cable to F-jack on antenna and slide on weather boot, Figure 6.

**STEP 6.** Install remaining mount base screws. Install the vent tube on the back of the mount base. (This is the side opposite the word FRONT.) The hole for the vent tube is shown in Figure 8.

**CAUTION: DO NOT seal hole in vent tube.** Put sealant around the outside of the vent tube, approximately 1/2" from end, Figure 8. Push the vent tube into the hole. The sealant will seal the hole as you push in. Leave approximately 2 to 2-1/2" of the vent tube extending from the hole. Put a small amount of approved sealant on the roof and under the vent tube to hold in place.

**FIGURE 7**

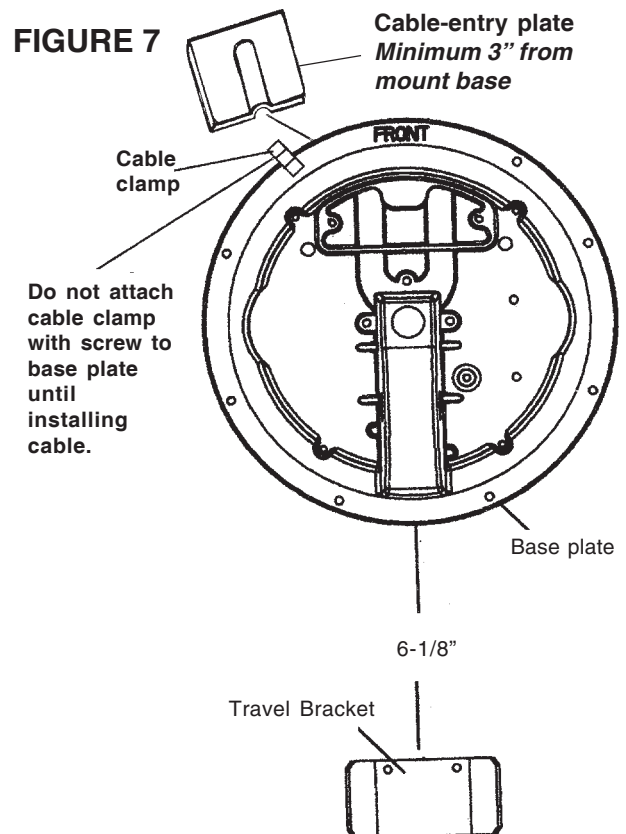

**FIGURE 8**

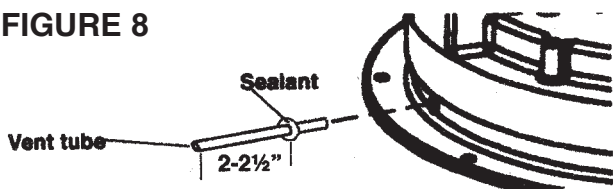

**CAUTION: DO NOT GET** sealing compound between base plate and Rotating Gear Housing.

**STEP 7.** Facing the front of the dish, find coax cables attached to side of the feed arm, Figure 9. Measure 24" of coax from this point and mark. **DO NOT CUT.** Rotate mount on base clockwise, fully, until it stops. Route coax around mount base, Figure 10.

Fasten cable clamp in hole in mount base (check roof template inserted in this manual for correct location) at end of the coax cable measurement.

**FIGURE 9**

Measure coax 24" from plastic tie wrap on left side of feed arm. (STEP 7)

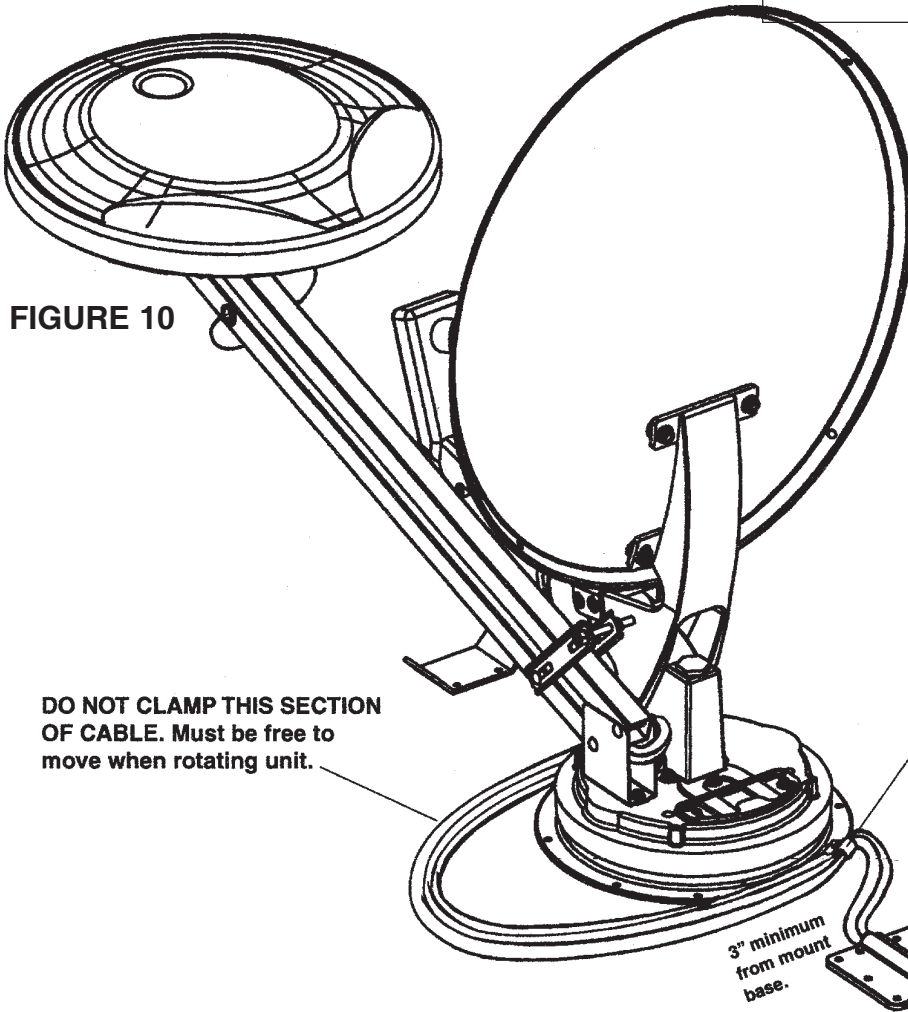
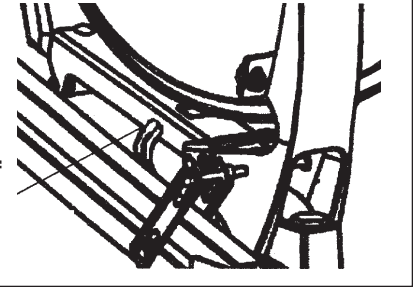

**STEP 8.** Feed coax cables through the roof. **Weather-proof cable** entry by applying sealant under the lip of the cable-entry plate and where cable enters roof. Attach plate to roof with screws provided. Apply sealant over screws and around edge of roof-through plate, making sure cable entry is sealed. Secure cables as necessary to prevent whipping. **If cable connections are exposed, be sure to weatherproof connection!**

**Mount travel bracket to roof 6-1/8" from base, Figure 7, page 6.**

**STEP 9.** Apply approved sealing compound to screw heads, cable entrance hole and edge of gasket under mount, **AFTER mounting**, Figure 7.

**STEP 10.** Attach satellite coax cable (with RG-6 printed on it) to the satellite receiver.

**STEP 11.** Attach RS-1000 coax download (with RG-59 printed on it) to RV-7542 power supply. Refer to power supply instruction sheet. You can connect the antenna

**ANOTHER METHOD OF INSTALLING ROOF CABLE/ ENTRY PLATE:** Attach cable to roof using cable clamp. Use sealant to seal screw heads.

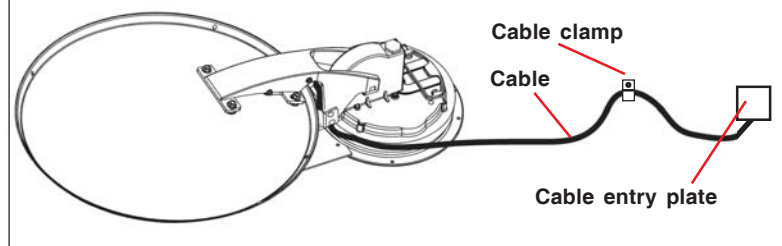

output from the power supply directly to the "TV ANT IN" on satellite receiver. (Refer to receiver manual.) This allows you to watch local channels when you turn off the receiver.

**STEP 12.** Connect digital elevation sensor at roof level, see top of page 8.

# FOR RM-DM61/RM-DM55 ONLY

## DIGITAL ELEVATION SENSOR ROOF CONNECTIONS

The illustrations below show the different methods of connecting wires at roof level. Method will depend on model. Wire colors MUST MATCH (i.e. red to red, green to green, black to black, white to white).

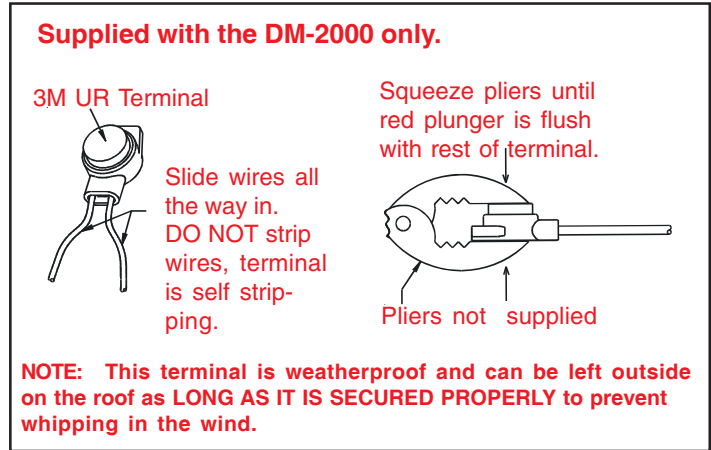
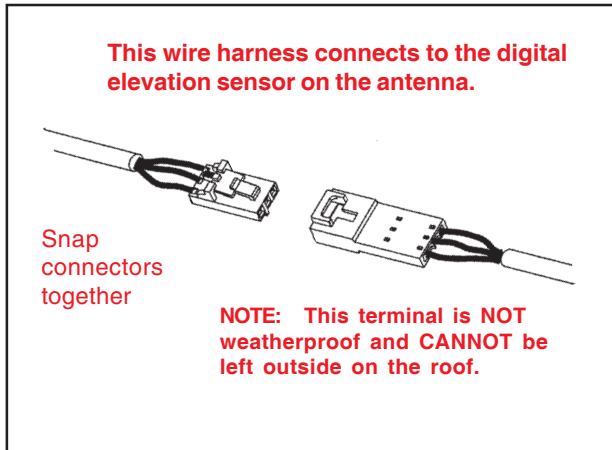

FIGURE 11

## INSIDE YOUR RV

**STEP 13.** Place the nut on the threaded rod.

**STEP 14.** Measure and cut the threaded rod with a hacksaw. Use the chart, Figure 11, to determine the length.

**STEP 15.** Remove the nut over the cut end of the threaded rod. This cleans the threads after cutting.

**STEP 16.** Thread the cut end of the rod into the hub,

**STEP 17.** Install the ceiling plate. The rotate/lock lever must point toward the rear of the vehicle.

**Be sure rotate/lock lever is pointing toward back of vehicle and hole in ceiling aligns with hole in the ceiling plate.**

**NOTE: Make sure large and small keyways line up in the hub and directional handle!**

**STEP 18.** Measure and cut the directional handle; see Figure 12 and chart, Figure 11. **NOTE:** A tube cutter is recommended for cutting the directional handle. This gives a square cut; a hacksaw does not. If using an extension, see Step 22, page 9.

Figure 13, page 9, shows what points to measure between, with *and* without a roof wedge.

Roof Thickness	Directional Handle Length (Figure 3E)	Threaded Rod Length	Worm Gear Shaft Length (Figure 3G)
1-1/2"	2-7/8"	2-3/4"	2-7/8"
1-3/4"	3-1/4"	3"	3-1/8"
2"	3-1/2"	3-1/4"	3-1/2"
2-1/4"	3-7/8"	3-1/2"	3-7/8"
2-1/2"	4-1/8"	3-3/4"	4-1/8"
2-3/4"	4-1/2"	4"	4-1/2"
3"	4-3/4"	4-1/4"	4-3/4"
3-1/4"	5"	4-5/8"	4-7/8"
3-1/2"	5-1/4"	4-7/8"	5-1/8"
3-3/4"	5-5/8"	5-1/4"	5-1/2"
4"	5-3/4"	5-1/2"	5-3/4"
4-1/4"	6-1/8"	5-3/4"	6-1/8"
4-1/2"	6-1/2"	6"	6-1/4"
4-3/4"	6-5/8"	6-1/8"	6-3/8"
5"	6-7/8"	6-3/8"	6-5/8"
5-1/4"	7-1/8"	6-5/8"	7"
5-1/2"	7-3/8"	6-7/8"	7-1/4"
5-3/4"	7-5/8"	7-1/4"	7-1/2"
6"	7-7/8"	7-1/2"	7-3/4"
6-1/4"	8-1/8"	7"	8"
6-1/2"	8-1/2"	7-3/4"	8-1/4"
6-3/4"	8-3/4"	8"	8-1/2"
7"	9"	8-1/4"	8-7/8"
7-1/4"	9-3/8"	8-5/8"	9-1/8"
7-1/2"	9-5/8"	8-7/8"	9-3/8"
7-3/4"	9-7/8"	9-1/8"	9-5/8"
8"	10-1/8"	9-3/8"	10"6-1/4"
8-1/4"	10-3/8"	9-5/8"	10-1/4"
8-1/2"	10-3/4"	9-7/8"	10-3/8"
8-3/4"	11"	10"	10-5/8"
9"	11-1/4"	10-1/4"	11"
9-1/4"	11-1/2"	10-5/8"	11-1/4"
9-1/2"	11-3/4"	10-7/8"	11-1/2"
9-3/4"	12"	11-1/8"	11-3/4"
10"	12-3/8"	11-3/8"	12"
10-1/4"	12-5/8"	11-5/8"	12-1/4"
10-1/2"	12-7/8"	11-7/8"	12-1/2"

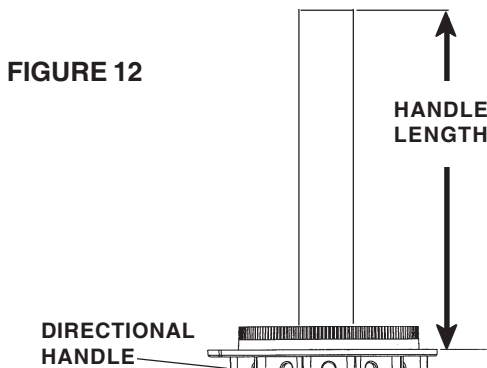
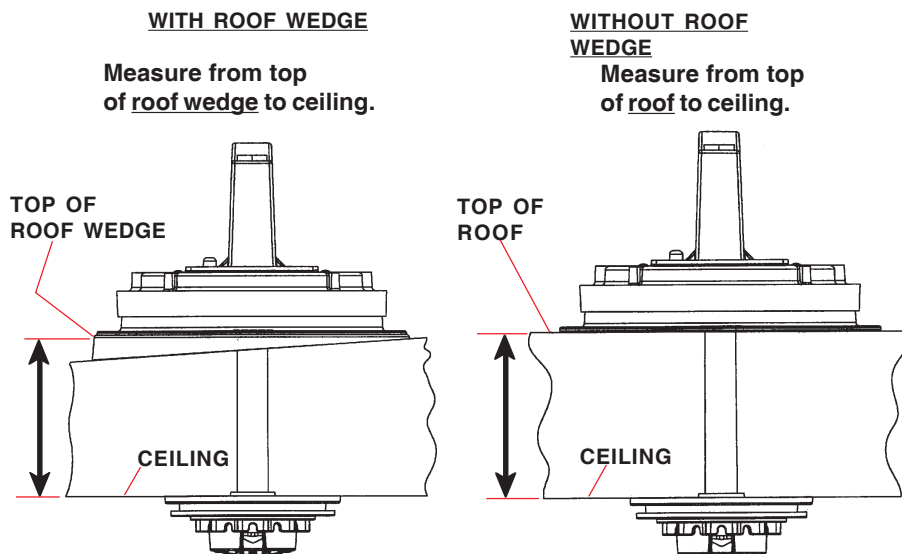

FIGURE 12

**STEP 19.** The directional handle and threaded rod will fit roofs up to 5-1/4" thick. If you are using wedges to compensate for roof/ceiling slope, be sure to allow for this extra thickness. You may add an extension to the directional handle for thicker roofs. Each extension will increase the length of the directional handle by 2-1/4".

**FIGURE 13**



**FIGURE 14**

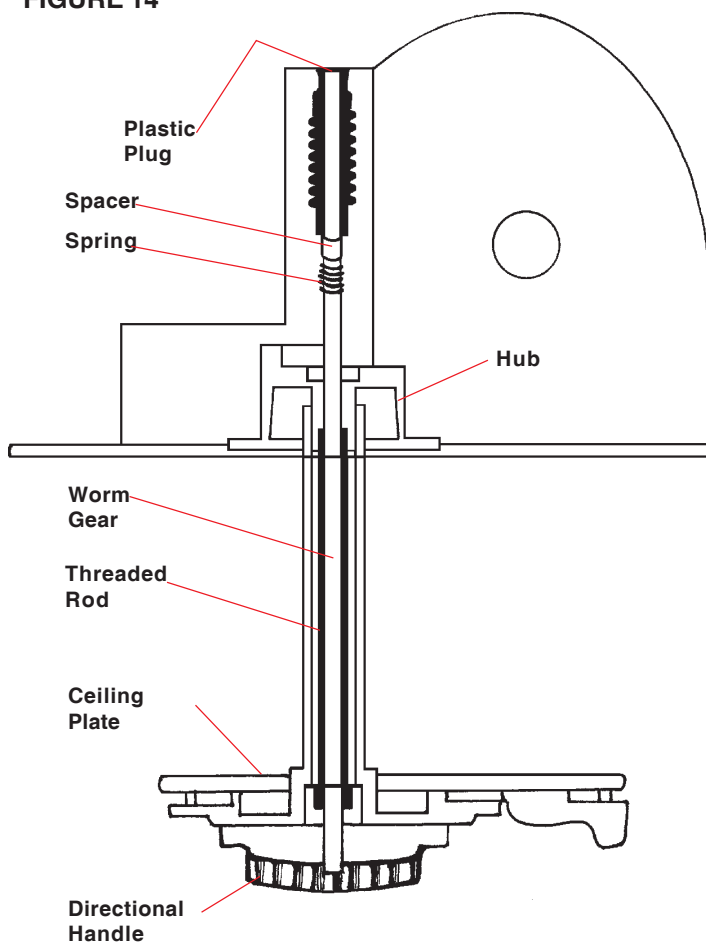

**STEP 20.** Press the directional handle onto the hub. Point the arrow on the directional handle towards the rotate/lock lever to orient to the splines.

**STEP 21.** Install the washer and nut on the threaded rod. Tighten the nut enough to snug the directional handle to the hub.

**STEP 22. IF YOU ARE USING AN EXTENSION,** adjust the total length of the directional handle and extension by **cutting the directional handle**. After adjusting parts for proper roof thickness, glue the extension to the directional handle. Use ABS (plastic pipe) glue.

**NOTE:** For roofs thicker than 5-1/4", a longer aluminum hex shaft will be needed. Contact Winegard Company for this part.

**CUTTING SHAFT**

**LENGTH, Figure 14A:**

Flip down handle on the elevating crank handle. Slide elevating crank handle up shaft until snug against directional handle. Mark the elevating shaft at inside bottom surface of crank handle housing, Figure 12. Cut shaft at mark, after removing crank handle. Reinstall crank.

**FIGURE 14A**

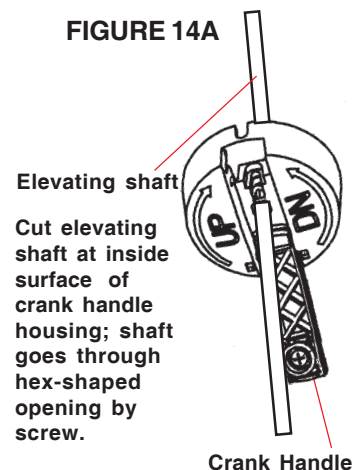

**STEP 23.** Check system for proper operation. Elevate dish with crank handle. A minimum of 14 turns is needed to elevate dish. Then, move directional handle with dish elevated. Directional handle should turn freely. If possible, have someone watch to make sure coax does not bind or interfere with dish movement.

**CAUTION:** After INITIAL INSTALLATION, the antenna should ROTATE APPROXIMATELY 360° FROM TRAVEL POSITION.

The pointer on the DIRECTIONAL HANDLE should point towards the RED SCREW on the ROTATION CLAMP when in TRAVEL POSITION.

FIGURE 15

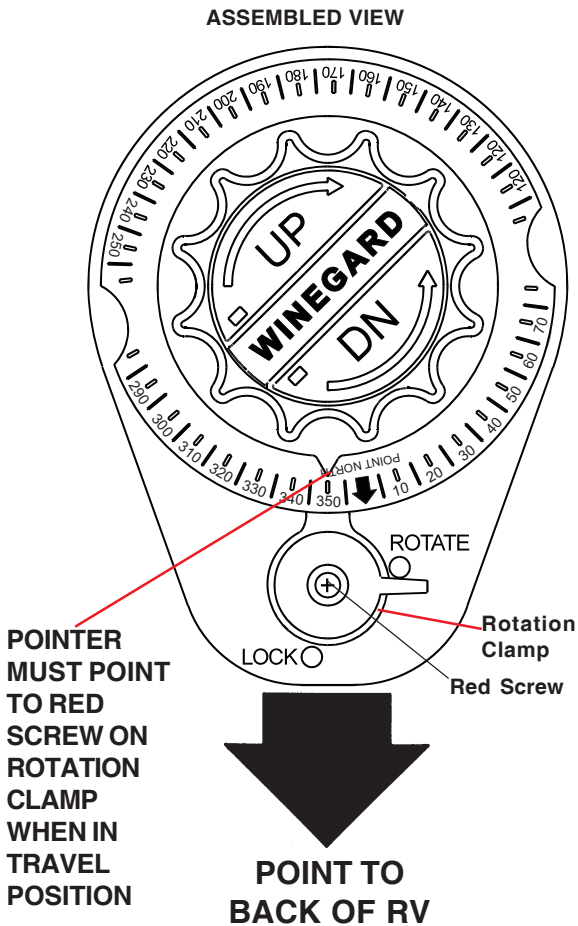

**CAUTION:** The antenna MUST BE IN THE TRAVEL POSITION before ALIGNING the Directional Handle and Ceiling Plate.

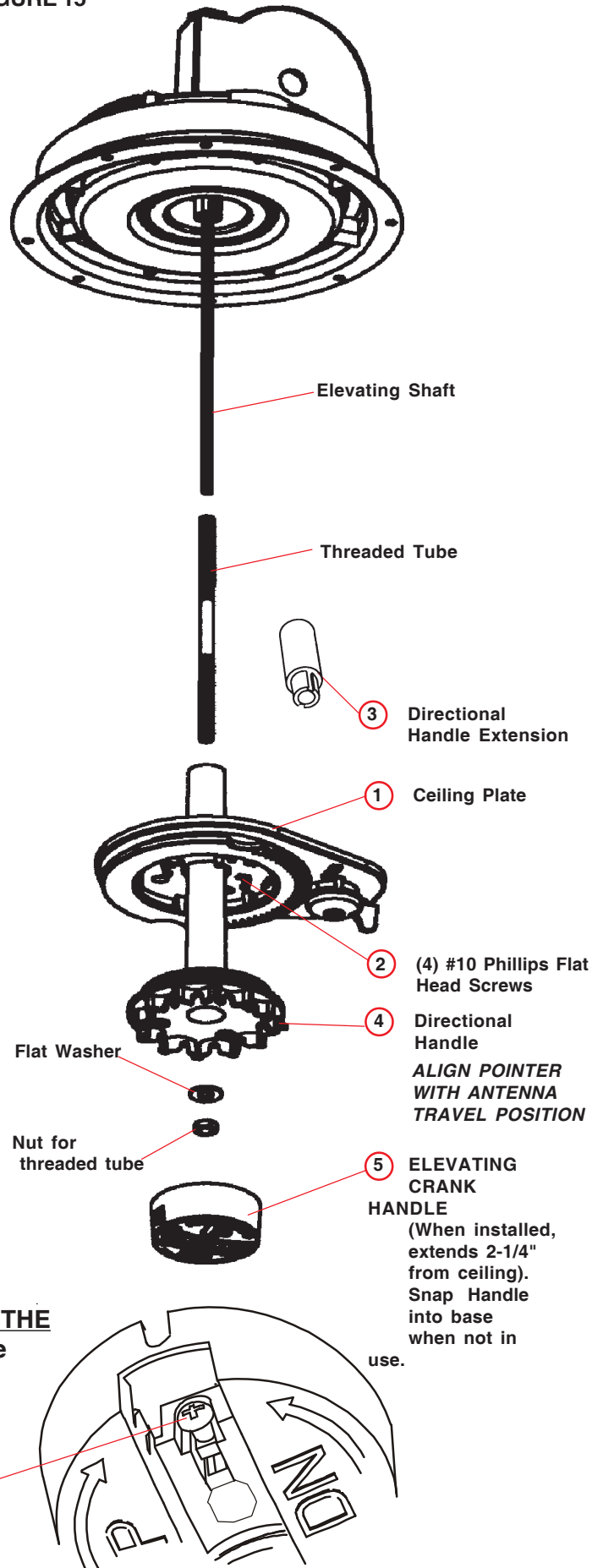

**EXPLODED PARTS VIEW**

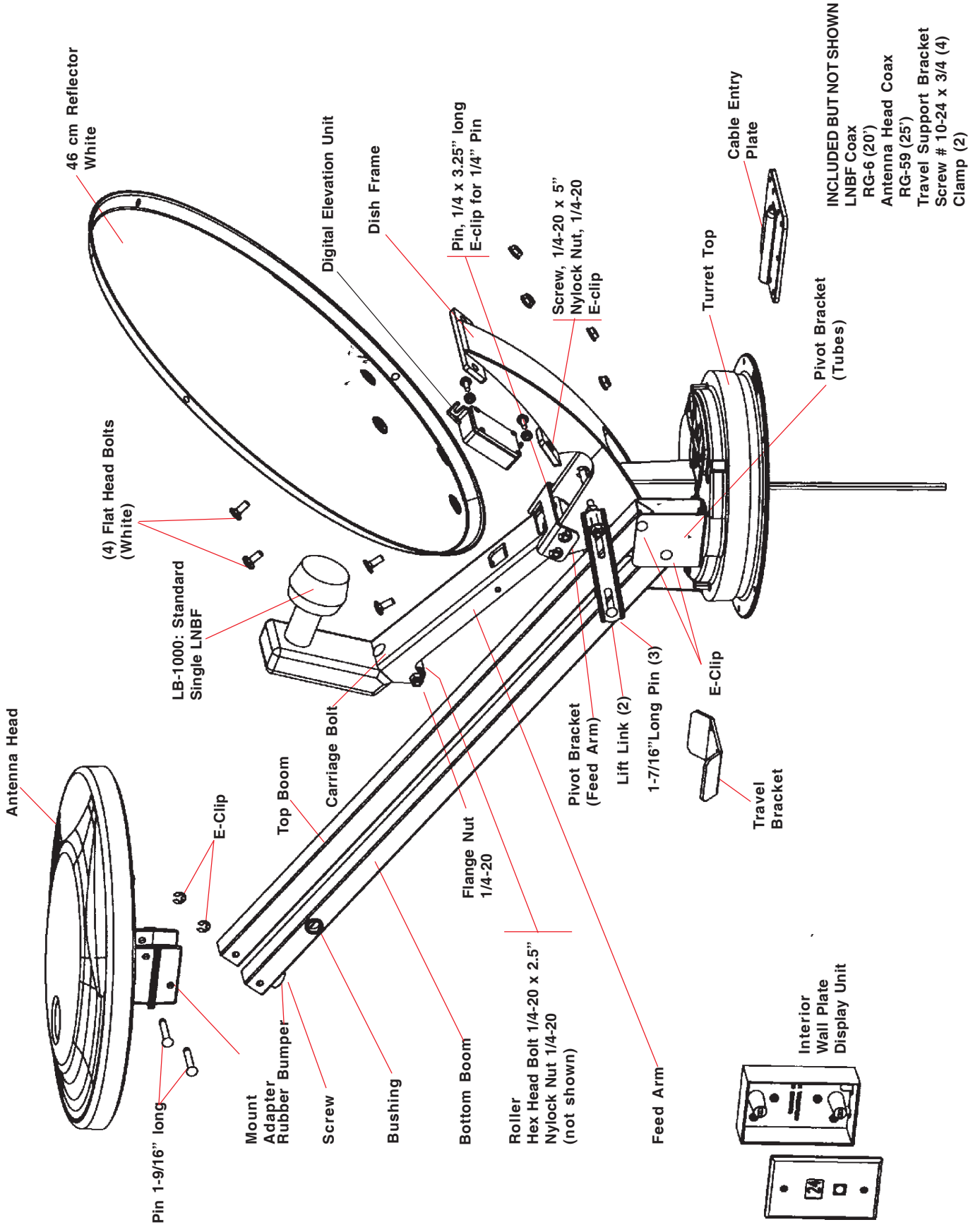

**PARTS LIST**

**INTERIOR  
HARDWARE KIT  
RK-CEIL**

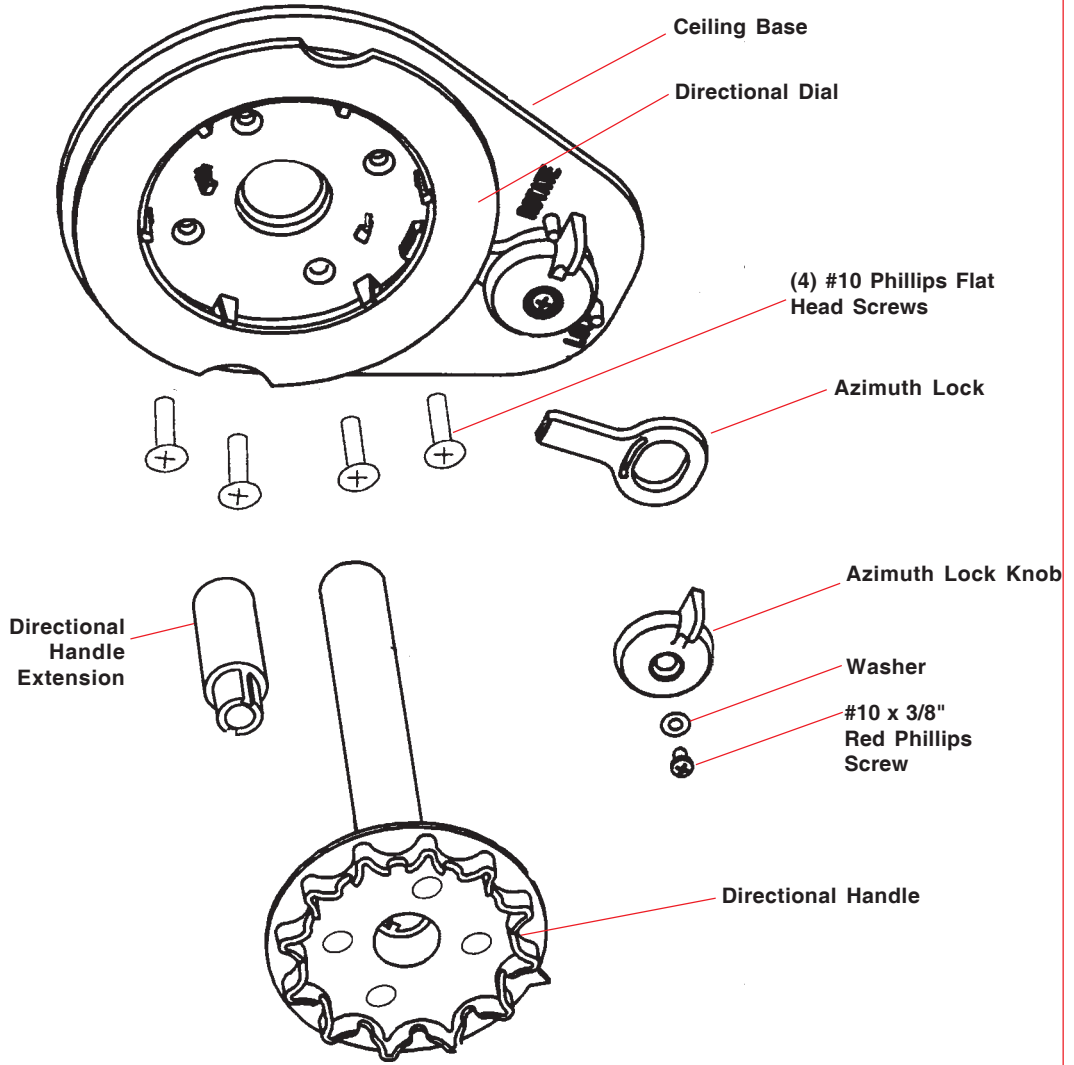

**CRANK HANDLE KIT  
RK-HAND**

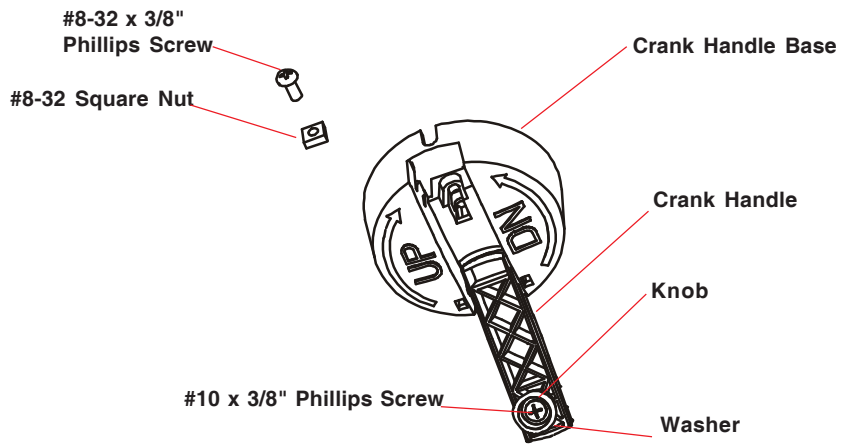

***NOT TO SCALE***

Rev 6/11/01

## SPECIFICATIONS

Height when raised .....	30" with satellite antenna in vertical position
Height in travel position .....	8"
Operating radius .....	35" (70" diameter circle)
Roof space required .....	19.5" x 46.75"
LNBF .....	Compatible with DISH Network®, DirecTV® and ExpressVu
Color .....	White
Satellite antenna height .....	20.9"
Satellite antenna width .....	19.5"
F/D .....	0.59
Offset angle .....	24°
Satellite antenna gain—	
11.2 GHz .....	33.22 dBi
12.1 GHz .....	33.89 dBi
12.6 GHz .....	34.23 dBi
Aperture efficiency .....	73%
Cross polarization (on axis) .....	-21 dB
*Beamwidth at -3 dB .....	3.5°
*Beamwidth at -10 dB .....	7.0°
RS-1000 antenna gain —	
VHF .....	15.5 dB average
UHF .....	19.5 dB average
RS-1000 antenna height .....	3.25"
RS-1000 antenna width .....	14.5"
Wind Loading .....	Up to hurricane force
Weight .....	19 lbs. maximum
Shipping weight .....	21 lbs.

## **REPLACEMENT PARTS KITS**

### **HEAD ASSEMBLY RP-RS00**

Head w/bracket and nut .....	1
Pins .....	2
E-Clip .....	2

### **REFLECTOR RP-REFL**

Dish .....	1
Bolt .....	4
Nut .....	4

### **BOOM ASSEMBLY RP-BOOM**

Top boom .....	1
Bottom boom .....	1
Bumper .....	1
Screw .....	1
Bushing .....	1
Lift link .....	2
Pin .....	3
E-Clip .....	4
Nut .....	2
Screw .....	1
Pivot bracket .....	1
Long bolt .....	1
Nylock nuts .....	2

### **BACKUP & FEED ASSEMBLY RP-BUFA**

Fram .....	1
Feed arm .....	1
Roller .....	1
Bolt .....	1
Nut .....	3
Bracket .....	1
Pin .....	2
E-Clip .....	3
Screw .....	1
Spring .....	1
Clamp .....	1
Screw .....	4

### **TURRET ASSEMBLY RP-9500**

Spring .....	1
Roll Pin .....	1
Gear for worm shaft .....	1
Elevation gear .....	1
Bushing .....	2
Seal .....	2
O-ring .....	1
Clamp .....	2
Shaft .....	1
Bearing, outer .....	1
Bearing, inner .....	1
Worm gear on shaft .....	1
Turret top .....	1
Turret base .....	1
Turret hub .....	1
Plug .....	1
Plate rotate limit .....	1
Screw .....	2
Gasket .....	1
Bracket .....	1
Screw .....	2
Pin .....	2
E-Clip .....	2
Pivot Bracket .....	1

### **GEAR KIT RP-GEAR**

Elevation gear (RMs) .....	1
Elevation gear (RVs & RDs) .....	1
Plug .....	1
O-ring .....	1
Wave washer .....	1
Quad ring .....	1
Flat washer .....	1
Washer .....	1
Extension .....	1
Worm gear, 16" shaft .....	1
Seal .....	2
Bushing .....	2

RD MODELS



## WINEGARD MOBILE PRODUCTS LIMITED WARRANTY

### (2 YEARS PARTS; 1 YEAR LABOR)

Winegard Company warrants this product against defects in materials or workmanship for a period of two (2) years from the date of original purchase. During year one (1) of such warranty, Winegard Company will also pay authorized labor costs to an authorized Winegard dealer to repair or replace defective products. No warranty claim will be honored unless at the time the claim is made, Customer presents proof of purchase to an authorized Winegard dealer (to locate the nearest authorized Winegard dealer, contact Winegard Company, 3000 Kirkwood Street, Burlington, Iowa 52601, Telephone 800-288-8094 or visit [www.winegard.com](http://www.winegard.com)). Customer must provide proof of purchase with a dated sales receipt for the Winegard product to verify the product is under warranty. If the date of purchase cannot be verified, the warranty period shall be considered to begin thirty (30) days after the date of manufacture.

If a defect in material or workmanship is discovered, Customer may take the product to an authorized Winegard dealer for service. Customer must provide proof of purchase to verify the product is under warranty. If the product is brought to an authorized Winegard dealer for service prior to expiration of year one (1) of the warranty period and a defect in material or workmanship is verified by Winegard Technical Services, Winegard Company will cover the Winegard dealer's labor charges for warranty service. The Winegard dealer must contact Winegard Technical Services in advance for pre-approval of the service. Approval of the service is at the sole discretion of Winegard Company.

Alternatively, Customer may ship the product prepaid to Winegard Technical Services (located at 3111 Kirkwood Street, Burlington, Iowa 52601, Telephone 800-788-4417). Customer must return the product along with a brief description of the problem and provide Winegard Technical Services with Customer's name, address, and phone number. Customer must also provide proof of purchase to verify the product is under warranty. If the product is returned before the expiration of the warranty period, Winegard Company will (at its option) either repair or replace the product.

This Limited Warranty does not apply if the product has been damaged, deteriorates, malfunctions or fails from: improper installation, misuse, abuse, neglect, accident, tampering, modification of the product as originally manufactured by Winegard in any manner whatsoever, removing or defacing any serial number, usage not in accordance with product instructions or acts of nature such as damage caused by wind, lightning, ice or corrosive environments such as salt spray and acid rain.

### RETURN AUTHORIZATION POLICY

A Return Material Authorization (RMA) is required prior to returning any product to Winegard Company or Winegard Warranty Services under this warranty policy. Please call our Technical Services Department at 800-788-4417 or send an e-mail to [warranty@winegard.com](mailto:warranty@winegard.com) to obtain the RMA number. Please furnish the date of purchase when requesting an RMA number. Enclose the product in a prepaid package and write the RMA number in large, clear letters on the outside of the package. To avoid confusion or misunderstanding, a shipment(s) without an RMA number(s) or an unauthorized return(s) will be refused and returned to Customer freight collect.

WINEGARD COMPANY DOES NOT ASSUME ANY LIABILITIES FOR ANY OTHER WARRANTIES, EXPRESS OR IMPLIED, MADE BY ANY OTHER PERSON.

ALL OTHER WARRANTIES WHETHER EXPRESS, IMPLIED OR STATUTORY INCLUDING WARRANTIES OF FITNESS FOR A PARTICULAR PURPOSE AND MERCHANTABILITY ARE LIMITED TO THE TWO YEAR PERIOD OF THIS WARRANTY.

In states that do not allow limitations on implied warranties, or the exclusion of limitation of incidental or consequential damages, the above limitations or exclusions do not apply.

Some states do not allow limitations on how long an implied warranty lasts, or the exclusion of limitation of incidental or consequential damages, so the above limitations or exclusions may not apply to you.

This warranty gives Customer specific legal rights. Customer may also have other rights that may vary from state to state.

### SATELLITE RECEIVER WARRANTY:

See manufacturer's limited warranty policy.

Rev. 2/08

