

WINEGARD®

Model HD-8800 UHF Antenna

WARNING

READ THE ACCOMPANYING SAFETY INSTRUCTION SHEET BEFORE PROCEEDING WITH ANTENNA AND/OR MAST ASSEMBLY AND INSTALLATION. INSTALLATION OF THIS ANTENNA NEAR POWER LINES IS DANGEROUS. FOR YOUR SAFETY, FOLLOW THE INSTALLATION INSTRUCTIONS.

Step 1. Unfold elements on reflector booms and driven element booms.

Step 2. Attach stacking booms to reflector booms with bolts and hex nuts supplied, Figure 1.

Step 3. Attach driven element booms to reflector booms with bolts and hex nuts supplied, Figure 1. Bolting together using the support braces on each side.

Step 4. Attach downlead connection with attached stacking bars to driven elements, Figure 2.

Step 5. Connect matching transformer (may not be included depending on model) to the coax cable downlead.

Step 6. Connect matching transformer to the downlead connection. Loosen wing nuts, and slide spade lugs of matching transformer between the washers. Tighten wing nuts securely.

Step 7. Mount antenna on top of mast and lightly tighten mast clamps.

Step 8. Connect the coax downlead to your TV, but do not secure at this time. Rotate antenna for best picture.

Step 9. Tighten the mast clamps securely, Figure 3.

Step 10. Secure coaxial downlead to the mast using tape to prevent whipping by the wind.

Step 11. Ground antenna and mast per accompanying Safety Instruction sheet.

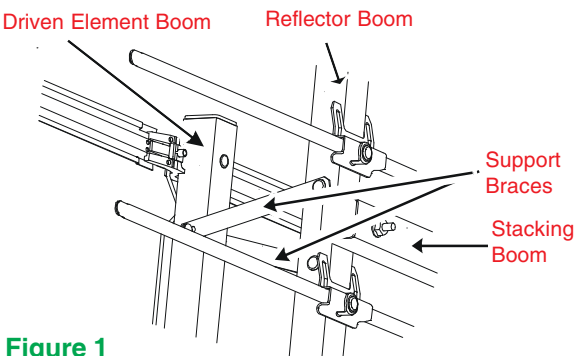

Figure 1

90 DAY LIMITED WARRANTY

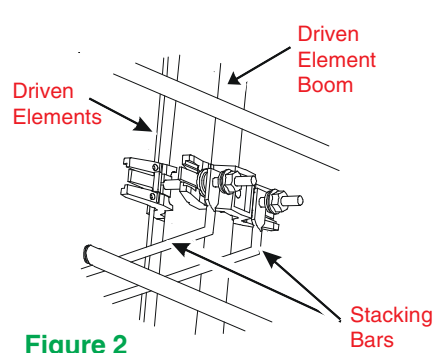
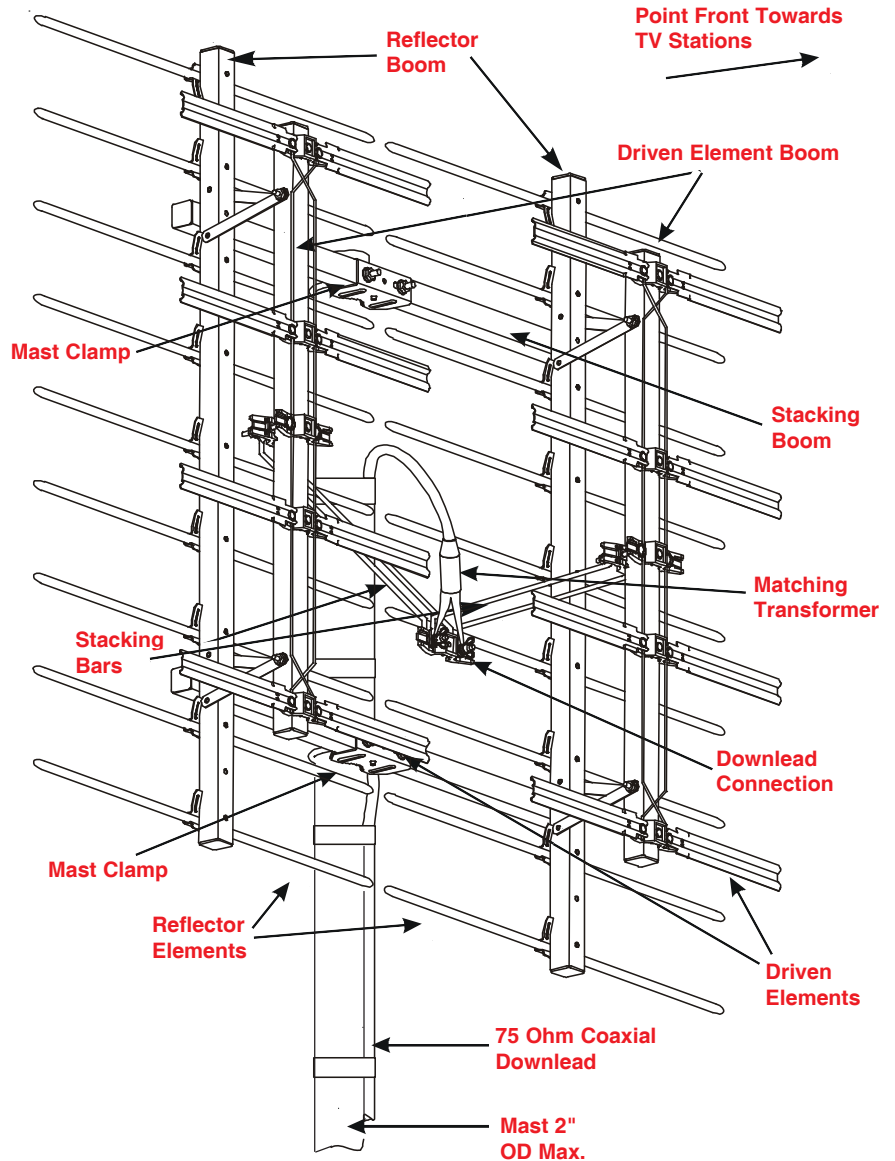

Figure 2

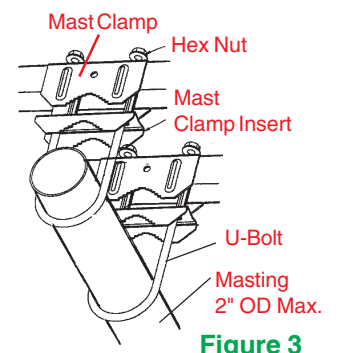

Figure 3