

90 DAY LIMITED WARRANTY

Winegard Company warrants this Winegard product against any defects in materials or workmanship within 90 (ninety) days from date of purchase. No warranty claim will be honored unless at the time the claim is made, you present proof of purchase to an authorized Winegard dealer (if unknown, please contact Winegard Company, 3000 Kirkwood Street, Burlington, IA 52601-2000, Telephone 800-288-8094).

Winegard Company (at its option) will either repair or replace the defective product at no charge to you. This warranty covers parts, but does not cover any costs incurred in removal, shipping or reinstallation of the product. This limited warranty does not apply if the product is damaged, deteriorates, malfunctions or fails from: misuse, improper installation, abuse, neglect, accident, tampering, modification of the product as originally manufactured by Winegard, usage not in accordance with product instructions or acts of nature such as damage caused by wind, lightning, ice or corrosive environments such as salt spray and acid rain.

The 90 Day Warranty is provided on the condition that the equipment is properly delivered with all handling and freight charges prepaid to your Winegard dealer for return to our factory for repair or replacement. Winegard dealers will arrange for the replacement or repair and return to you without charge the product which failed due to defective material or workmanship.

WINEGARD COMPANY WILL NOT ASSUME ANY LIABILITIES FOR ANY OTHER WARRANTIES, EXPRESS OR IMPLIED, MADE BY ANY OTHER PERSON.

ALL OTHER WARRANTIES WHETHER EXPRESS, IMPLIED OR STATUTORY INCLUDING WARRANTIES OF FITNESS FOR A PARTICULAR PURPOSE AND MERCHANTABILITY ARE LIMITED TO THE 90-DAY PERIOD OF THIS WARRANTY.

The foregoing shall be the sole and exclusive remedy of any person, whether in contract, tort or otherwise, and Winegard shall not be liable for incidental or consequential damage or commercial loss, or from any other loss or damage except as set forth above.

Some states do not allow limitations on how long an implied warranty lasts, or the exclusion of limitation of incidental or consequential damages, so the above limitations or exclusions may not apply to you.

This warranty gives you specific legal rights and you may also have other rights which vary from state to state.

Rev. 2/08



INSTRUCTIONS

UHF ONLY

MODELS

HD-9022 & HD-9032

WARNING

INSTALLATION OF THIS ANTENNA NEAR POWER LINES IS DANGEROUS. FOR YOUR SAFETY, FOLLOW THE INSTALLATION INSTRUCTIONS.

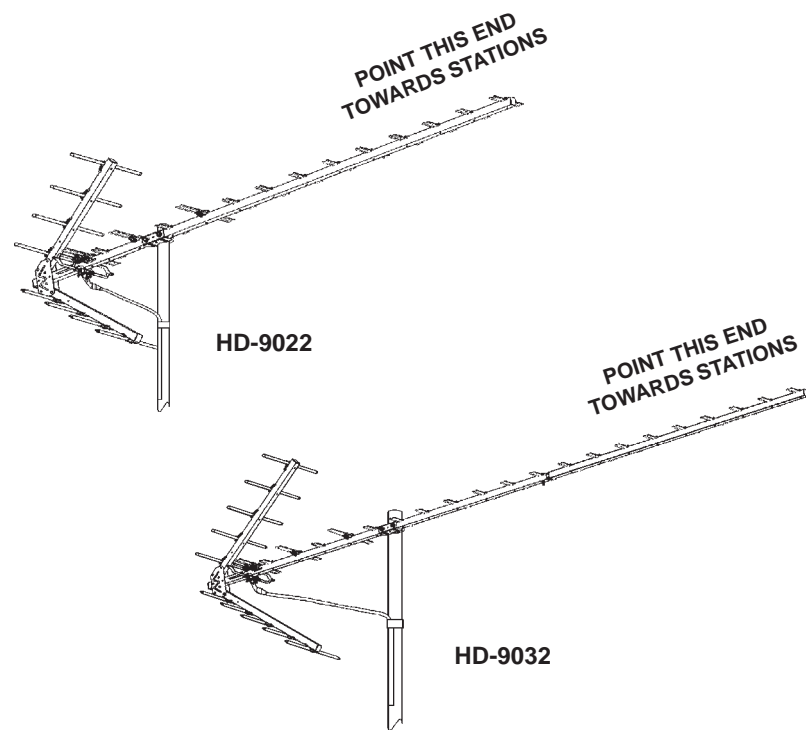

STEP 1. Unfold the elements on the top and bottom reflector booms. Swing the elements out until they lock into position. See Figure 1. Unfold reflector booms until they lock into place. See Figure 2.

STEP 2. Unfold all elements making sure they lock into place.

MODEL HD-9032

STEP 3. Remove the bolt and hex nut holding the element on the tapered end of the front boom. Slide the two sections together. The elements should be on top. Replace the element, bolt and hex nut and tighten securely. See Fig. 3.

STEP 4. Be sure to unfold tetrapole elements away from boom.

STEP 5. Connect matching transformer to the downlead connection. Loosen wing nuts on the **bottom** side of the tetrapole, and slide spade lugs of matching transformer between the washers. Tighten wing nuts securely. See Figure 4. If a VHF antenna is coupled in with this antenna, the VHF lead attaches to the top set of connections on the tetrapole. **Note: If you are coupling a VHF/UHF antenna to the top VHF tetrapole connections, you will lose CH.14-69 from the VHF/UHF antenna.**

STEP 6. Remove the mast clamp insert, U-bolt, and hex nuts from the supplied hardware bag. Align insert with mast clamp on main antenna boom. Attach U-bolt through mast clamp insert and holes on the side of main boom, extending threaded bolt ends through holes to allow finger tightening of hex nuts to boom. Mount antenna to the mast by sliding U-Bolt through top of mast, keeping mast between the rounded U-bolt edge and the insert. Tighten hex nuts securely to lock the antenna to the mast, keeping main antenna boom level. See Figure 5.

STEP 7. Tape coax to mast with a good quality electrical tape to prevent wind whipping.

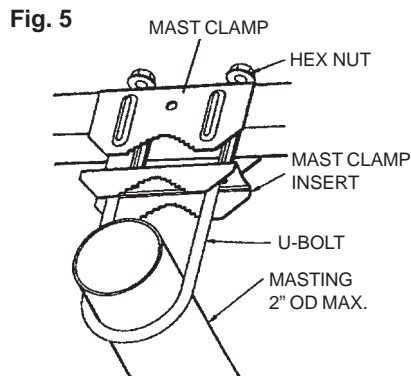
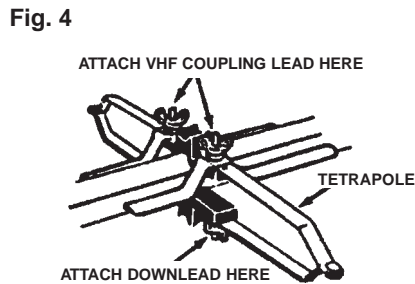
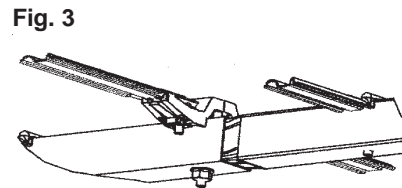
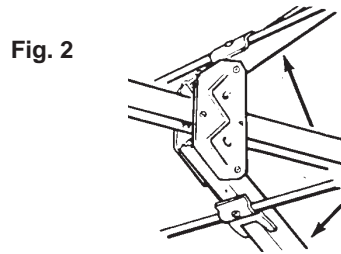
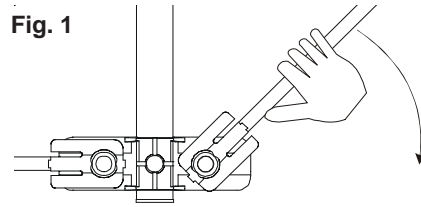

STEP 8. Ground antenna and mast per Safety Instruction Sheet. See Figure 6.

HOW TO PROVIDE LIGHTNING PROTECTION FOR TV ANTENNA AND SET

Fig. 6

Step 1. Mount the grounding block as close as possible to where the 75 ohm coaxial cable downlead enters the house. See Fig. 6.

Step 2. The ground wires for both the mast and the downlead should be copper or aluminum wire, number eight (8) or larger. See Figure 6.

Step 3. The downlead wire from the antenna to the grounding block and the mast ground wire should be secured to the house spaced from four (4) to six (6) feet apart. See Figure 6.

NOTE: In the case of a "ground up" antenna installation, it may not be necessary to ground the mast if the mast extends four or more feet into the earth. Consult a TV serviceman for the proper depth in your location.

