

# Winegard Dome Satellite Systems

---

- I. Winegard's FAST
- II. Movin' View<sup>®</sup> and Minimax<sup>™</sup> 15" Domes, RoadTrip<sup>®</sup> and Mission<sup>™</sup> 12" Domes
  - a. Painting of Domes
  - b. Installation
    - i. Roof
      - 1. Obstructions
      - 2. Mounting requirements
      - 3. Setting switches
    - ii. Interior
      - 1. Clean source of power
        - a. Dedicated line
        - b. Power supply
  - c. Receiver Setup
    - i. DIRECTV- "Oval two dish satellite" or "oval 3 for HD"
    - ii. DISH Network- SW42 Switch or SW64 for HD
  - d. Troubleshooting
  - e. Features and Benefits
    - i. On-Off Operation
    - ii. DVB
    - iii. Seamless Guide
- III. Test



# WINEGARD® RV AUTOMATIC SYSTEMS ARE **F.A.S.T.** IN-MOTION & STATIONARY

---

**F** AST ACQUISITION - OF DESIRED SATELLITE  
TYPICAL SEARCH TIME IS 1-2 MINUTES (GPS &/OR DVB)

**A** CCURATE IDENTIFICATION - OF DESIRED SATELLITE  
DESIRED SATELLITES ARE **POSITIVELY IDENTIFIED** (DVB)

**S** IMPLE USER OPERATION - ONE BUTTON - ON/OFF SWITCH  
TURN SYSTEM ON, IT FINDS SATELLITE, YOU WATCH SATELLITE TV

**T** RUE AUTOMATIC TOGGLE - ON SCREEN - SEAMLESS GUIDE  
ROAD MAP – TO NAVIGATE THE HUNDREDS OF CHANNELS ON BOTH  
PRIMARY AND ALTERNATE SATELLITES.

---



IN-MOTION &/OR STATIONARY



# Winegard® Domed Antenna Installation

*Note: Please take out the Winegard Movin' View® and RoadTrip® MiniMax™ and Mission™ satellite system installation/operation manuals and follow along. This course will not cover every aspect of the manuals, but will focus on key points. Please read the manual at your convenience.*

***Note: Winegard Company does not recommend painting the satellite dome as signal loss may result.***

## Installation (Roof)

- Winegard satellite systems cannot be installed in wet conditions. Attempting to install in wet conditions will result in faulty electronics.
- It is necessary to install the system while the RV is level and on a level location on the roof. Refer to the chart packaged with the antenna to ensure the satellite system is located the correct distance from obstructions.
- It is necessary to follow the satellite mounting instructions step by step in order for an in-motion satellite system to track correctly.
- Remove the dome and store it in a safe place while attaching the feet as shown in the instructions. You will now level and mount the unit as shown in the instructions, ensuring correct installation.
  - Note: Refer to your RV manufacturers recommended roof sealant when sealing the feet of the satellite system's base.
- After successfully leveling and sealing the satellite system to the roof, you will want to add a second coaxial cable to the system *if the customer will be using two receivers*. Push the coax (without a connector) through the opening. Ensure the coax is secured and will not affect dish rotation and seal the connections.
  - *Note: Be sure to mark the secondary coax so you don't confuse it with the primary coax. Only the primary receiver will control the satellite system's toggling.*
  - *Note: Connections on the MiniMax and Mission are all conveniently located on the outside.*
- The Movin' View and RoadTrip MiniMax and Mission antennas have switches in the unit which must be set according to the customer's satellite programmer. The units come preset for DIRECTV and must be changed if they use DISH Network or Bell TV (ExpressVu). Instructions for how to do this can be found in the installation manual.
- When deciding the correct installation location for the cables, it is sometimes useful to remove the RV's front television system to locate the best place for cable routing. Secure the cables in place with the plate. Do not seal the cable plate until installation has been completed and tested.
- The technician installing the unit should not put the dome in place until the unit has been tested once to ensure successful installation.

## Installation (Interior)

- The installation manual details the correct way to install the power switch. **A good filtered source of power is required.** Go directly to the battery if possible or use a separate Winegard power supply (part #2780466).
  - *Note: The switch will get warm when left on. It is simply the heat generated by the light in the switch. **This is normal.***

## Receiver Setup (Keys to successful Operation)

- Both DISH Network and DIRECTV have programming on multiple satellites. The primary receiver will control the toggle function which will enable the customer to watch all available programming.
  - Note: Toggling is the movement of the dish from one satellite to another automatically upon selecting a channel with the remote.
- For DIRECTV programming the receiver must be set to “Oval Dish, 2 Satellites.” See the receiver user’s guide for set up instructions.
- For DISH Network systems you must perform a check switch test within 6 minutes of the unit locking on the correct satellite. For specific instructions on how to perform a check switch test refer to the receiver’s owners manual.
  - Note: Successful check switch test results will show both satellites 119 and 110 each having odd and even transponders. It will also list switch “SW42” as installed. RoadTrip MiniMax will list SW64.
  - Note: The secondary satellite must be set up on the primary coax cable from the dish to pass the check switch test. This allows the secondary receiver to automatically download program guides from both satellites. **This must be done before the receiver is moved to the secondary coax.**
  - **Once a successful check switch test has been completed, it should not need to be performed again unless the receiver has been used with another satellite system or it shows something other than switch “SW42 or SW64” installed.**
- The MV3500A or RT8000S satellite systems cannot successfully toggle between satellites unless the power to the satellite system has been left on.

## Troubleshooting

- If the satellite system searches but will not lock on signal, verify that the receiver is turned on and supplying voltage to the LNB.
- Excessive dew, rain, and snow can interrupt signals and cause the satellite to fail its search. It is also important to check the southern sky for obstructions if satellite acquisition fails.
- If using DIRECTV and the Winegard satellite dish will only lock on to the alternate satellite, verify that the switches located under the satellite dome are set correctly.

## Features and Benefits

- One-button (On/Off) operation minimizes customer input.
- DVB technology assures customer of accurate and fast satellite acquisition
- Dual receiver capable
- Automatic Toggle
- Seamless guide allows the viewer to see all available channels at once without pressing a satellite select switch.

# Basic steps of operation for Stationary Movin' View and RoadTrip Models Using DVB

## Helpful when Troubleshooting

Turn on the power. The dish will raise up and take a base line noise ratio, meaning any signal more than this is a satellite signal (something like the static you hear on an AM radio.). Then the dish will rotate clockwise. After the limit switch is tripped, the dish will then rotate counterclockwise, and stop with the LNB mostly over the electronics box. This is called the **Home Position**. The Minimax stops with one corner of the electronics near where the cables exit.

- **If this doesn't happen.** Check to see if the power is on and test for power at the supply leads for the electronics box. Check the fuse in the electronics box.
- **Then it will begin its search.** The dish will rotate and stop (pause) when it finds a satellite then move on to find and pause on other satellites, including the primary satellite. This information is used in conjunction with the DVB (Digital Video Broadcast) signal identifier built into the MV3500A, to verify that it has found and locked onto the correct satellite. The dish will finally move and stop at the selected satellite. Viewing of the programming can begin. This information should be explained to the customer, you could find it on page 3 of the dish manual.
- **The Minimax no longer uses EL and AZ limit switches.**

## Basic steps of operation for Models with GPS and DVB.

- **Helpful when troubleshooting.**
- **Tracking, while In-Motion.**
- **In-motion Movin' View Models, RoadTrip Minimax, LP-1000 and RoadTrip models.**

The satellite system has two modes of operation.

- **Tracking mode:** In this mode the unit will search and actively follow the satellite as you drive. This will continue for 6 minutes after motion has stopped, or if stationary 6 minutes after it has locked on to the primary satellite.
- **Sleep mode:** This is where the dish will toggle satellites as channels are changed with the receiver remote. Going further, the five basic steps of operation are: **Home, GPS, Search, Tracking and Sleep modes.**

**Home:** Inspect the unit with the dome off to see if the satellite system has a 720 degree rotation with limit switches. See the information provided earlier that matches the type of system you are working with.

**GPS:** To acquire GPS the dish should be in the home position. This can take up to 10 minutes on the initial search. After that, the search time is normally 1 to 2 minutes. If the unit has moved to a new location that is over 600 miles from the last time it was used, it may take longer than the 1 to 2 minutes, because the GPS may take longer to figure out where it is.

**If this doesn't happen.** See page 5 of the Troubleshooting Guide for more information.

**SEARCH:** After the unit has acquired GPS, the dish will begin its search. The dish will set the initial search elevation and begin searching for satellites. After finding and verifying (by moving off the signal and returning to the signal) that it has the correct satellite, the unit will continue to track the signal.

**If this does not happen.** Check the switches versus the mounting position of the system. Check to see that the receiver is on and supplying voltage to the LNB.

**Tracking Mode:** The dish makes short movements while locked on to the signal and will track in-motion. If the signal was lost (trees for an example), in some situations it will enter search mode again.

**Sleep Mode:** If no motion has occurred for 6 minutes, the dish will go into sleep mode; no movement of the dish and locked on to the signal. The system will **Toggle** between both the primary and the secondary satellites. Both DIRECTV and DISH Network have programming on more than one satellite. This means that if a channel is selected with the remote control that is not on the satellite currently selected, the system will automatically move to the desired satellite.

**To re-enter tracking mode, the unit must move forward in a straight line at a minimum of 10 MPH. Note: You may want to go 12 MPH to compensate for speedometer error.**

## How to identify a MV common base unit



### Wall Plate

Winegard's "W" logo was added to the left of Winegard.



### Electronics label

The word "**COMMON**" was added to the bottom of the electronics serial tag. Also, "**MVT**" or "**MVA**" was added to the electronics serial tag to identify if the unit is a tracker or stationary.



### Mechanical label

The word "**COMMON**" was added to the bottom of the mechanical label.

## MV3500A/MV3535A/MV3500T/MV3535T Replacement Kits

Kit for	Replacement part for Original MV base Dishes w/3 Feet	Replacement Part for MV Common base Dishes w/4 Feet
Electronics	RP3500A/RP3500T	RP35CBA/RP35CBT
Elev Motor	RP-MVEL	RP-CBEL
Az Motor	RP-MVAZ	RP-CBAZ
Limit Switch	No Original Part	RP-CBSW
LNB	LB-6000	LB-7000
Dome	RPDOMEW/RPDOMEB	RPDOMEW/RPDOMEB

The original replacement parts **will still be used** on Movin’View units that have 3 mounting feet.

The common base replacement parts are used for Movin’View units that have 4 mounting feet.  
The preceding page shows other ways of identifying “Common base Units”.

You must use the correct part or the unit will not perform satisfactorily.



# WINEGARD® CARRYOUT®

automatic portable satellite antenna

## Quick Start Guide

Before using your Carryout for the first time, there may be some initial steps required to set up your Carryout for use with your receiver. This is a one-time process. Follow the steps here for a typical installation. If you have any additional questions, consult our full Users Manual.



## 2) Wiring the Carryout

Connect the supplied Power Cable and Coaxial Cable to the Carryout as shown here.

The Coaxial Cable needs to run **DIRECTLY** to the **Satellite In** port on the back of the Satellite Receiver. If wiring through a wall plate on the side of the coach, consult **Using Outside Receptacle** steps on back.

The Power plug needs to be connected to a 12V power source

- or -

connect to an AC to DC power converter (like GM-1200 below).

Then plug converter into 110V outlet.

If using a Power Converter, it must be able to supply up to 5 amps of current.

**Before plugging in power, be sure that your satellite receiver is setup for use with the Carryout, as shown inside this guide.**



## 1) Programming the Carryout

The Carryout comes factory pre-set for **DIRECTV®**. DISH Network® users follow the steps shown below. DIRECTV users can skip to **Wiring the Carryout**.

First you'll need to identify the electronics box on the Carryout. After removing the dome, you will find the main electronics housing located directly behind the reflector.



On the side of the electronics board, you will see the **Dip-Switches** that control what Service Provider the Carryout is set for. It is factory pre-set for DIRECTV with the **8th switch down**.



Factory pre-set for DIRECTV



To set for DISH Network, push the **4th and 7th switches down**, and leave the **8th down**.



DISH Network settings

There are additional switch options shown in the Carryout manual for alternate DISH Network settings or Bell TV® settings.

## Using Outside Receptacle

**TIP:** If you are having problems, connect the Carryout coaxial cable directly to the receiver by running it through your RV door first to ensure it is running properly.

If your outside TV receptacle is wired for **satellite**, you'll need to locate where that receptacle leads and connect that directly to your satellite receiver.

If the outside TV receptacle is wired for **cable**, the wiring will have to be modified for use with satellite. The coaxial cable cannot run through any other devices or switches **BEFORE** the satellite receiver.



Cable

Typically, if wired for cable the wiring will either run through a Winegard Power Supply or Video Switch. The easiest way to fix this is to disconnect the cable from that device, use a barrel connector, and connect a new cable that runs directly to the receiver, bypassing the Power Supply or Video Switch.



[www.winegard.com](http://www.winegard.com)  
Technical Service: 800-788-4417



Winegard Company • 3000 Kirkwood St. • Burlington, IA 52601-2000  
800/788-4417 • FAX 319/754-0787 • [www.winegard.com](http://www.winegard.com)  
Printed in U.S.A. ©2010 Winegard Company Rev 5/10 2452201

Winegard and Carryout are registered trademarks of Winegard Company. DISH Network is a registered trademark of EchoStar Satellite L.L.C. DIRECTV is a registered trademark of DIRECTV, Inc., a unit of Hughes Electronics Corp. Bell TV is a registered trademark of Bell Canada, Inc.



# Domed Satellite Troubleshooting Tips

---

If the satellite dish doesn't seem to be working properly, follow the steps below to help get the dish back to regular operation.

If the satellite system has a mechanical problem that you can see or hear, go directly to step 7.

- 1) **Obstructions-** Is there anything that could block the signal? The satellites are in the southern sky and the dish needs direct line of sight to the satellite. Things that could block the signal are, but not limited to, trees, buildings, and power wires.
- 2) **Receiver-** Is the receiver set up as shown in the manual for the subscription provider (DIRECTV or DISH Network or Bell ExpressVu)? If the receiver is not setup correctly, often times it will not allow for regular viewing. See pages 25-27 for Set-up.
- 3) **Power-** Bad power can cause improper operation. Substitute the AC power to the receiver; try using an extension cord from a building. If that doesn't correct the operation, try substituting the 12 VDC to the dish. Use a Winegard approved power supply or a charged 12 volt battery.
- 4) **Dip Switches-** The dish has switches on the electronics that must be set correctly for the service provider and mounting option.
- 5) **Coax-** Substitute a known good coax that is RG-6 and has 2.25 GHZ or higher written on it. Run the coax from the electronics in the dish directly to "Satellite In" on the receiver, usually routed through a window or door.
- 6) **Substitute the satellite receiver-** Sometimes it's the receiver. Winegard recommends using a **single input non-recording receiver**. For DIRECTV, use a D10, D11, D12, H10 or H20. For DISH Network, a DISH 311 is recommended. HD receivers which do not record to a hard drive are recommended, Vip 211k.
- 7) **Troubleshooting Guide-** Follow the steps in the attached troubleshooting guide.
- 8) **DO NOT USE** A/B switches, video switches or splitters between the satellite dish and the satellite receiver. The use of multiplexers is not recommended with any Winegard satellite system as the receiver may not operate to the customer's satisfaction.
- 9) **Satellite antenna searches without stopping on signal (finding a sat signal)-Cause:** No power to the LNB (the sat receiver supplies this voltage). Check the coax for voltage from the receiver to the LNB or a defective LNB. *NOTE: Some of the above tips could simulate this condition, example an obstruction.*
- 10) If the concern hasn't been resolved, call Winegard Technical Services at 1-800-788-4417. Hours are 7:30 AM - 6 PM Monday-Friday, 8 AM – 4 PM Saturday, Central time.

# RoadTrip® Replacement Kits

All RoadTrip Models  
STATIONARY (RT1200S, RT1235S)  
IN-MOTION (RT1200T, RT1235T)

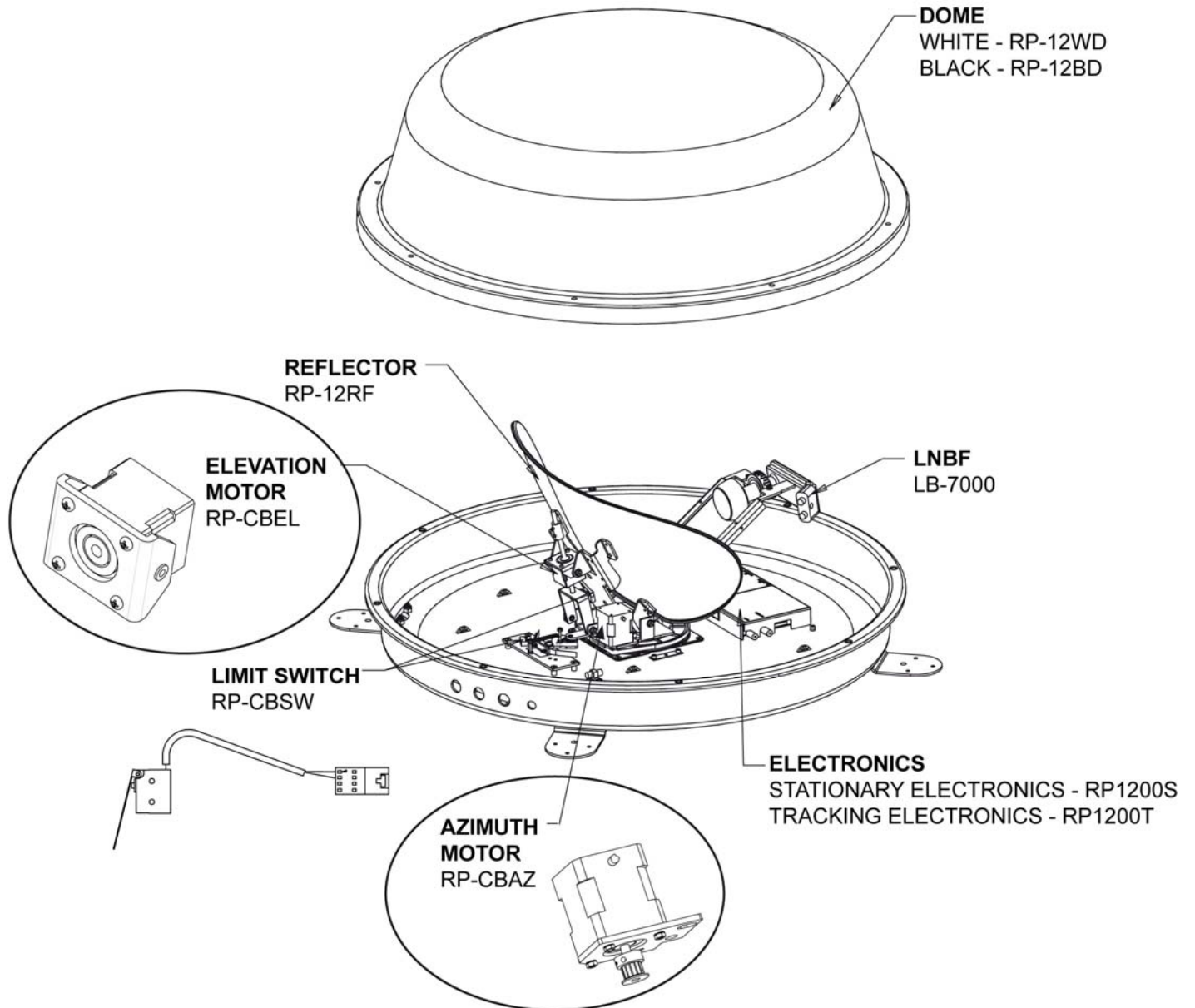

**OTHER KITS AVAILABLE:**  
**STATIONARY TO IN-MOTION UPGRADE KIT**  
RT-1205

**LEVELING KIT**  
RT-5012



# WINEGARD® CARRYOUT® ANTENNA REPLACEMENT PARTS

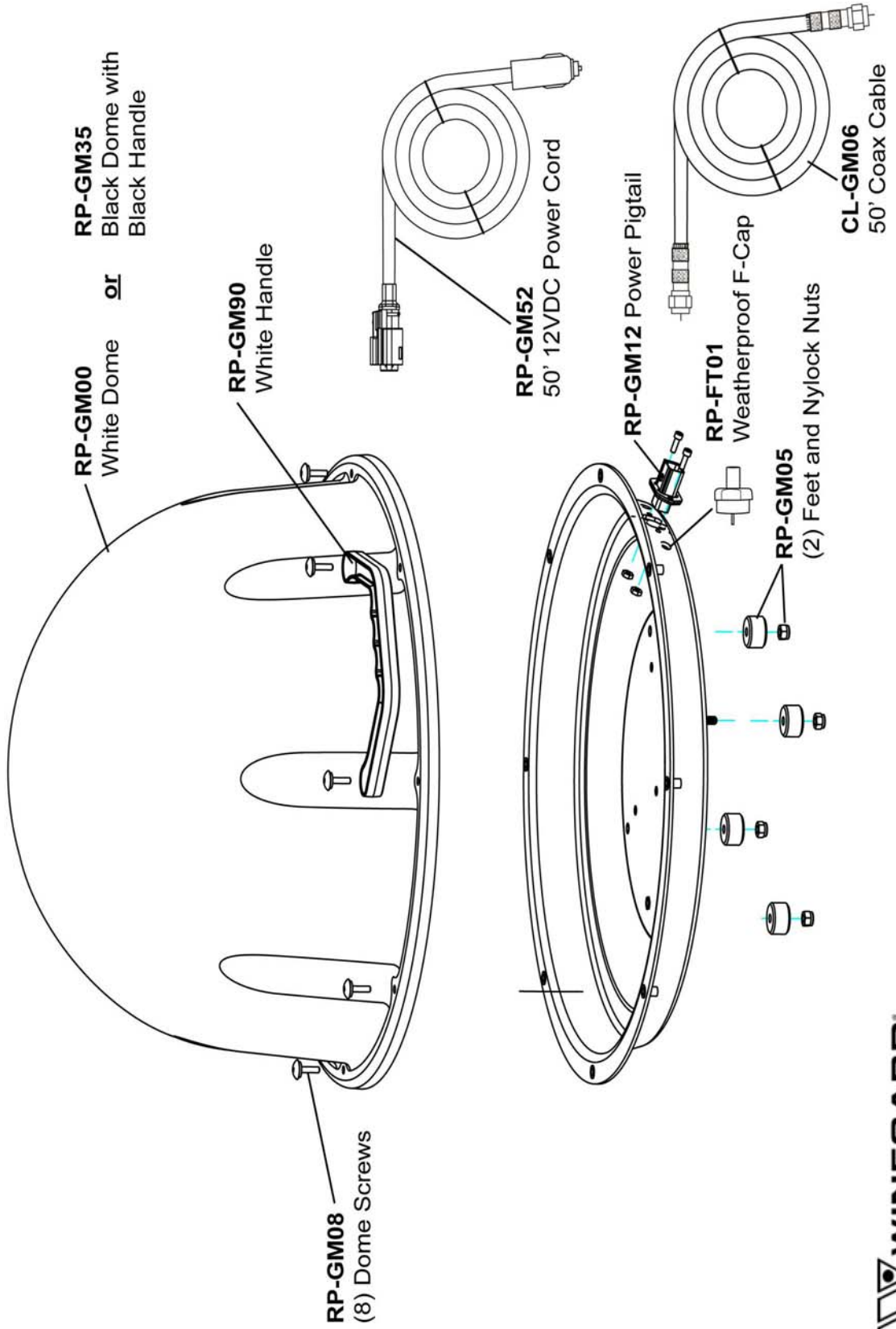



## MV Troubleshooting Guide

This troubleshooting guide assumes the users familiarity with the MV3500A and the MV3500T and the receiver set-up requirements. For any questions please refer to Pages 3-4 in the MV3500A manual and Pages 3-4 in the MV3500T Operation manual.

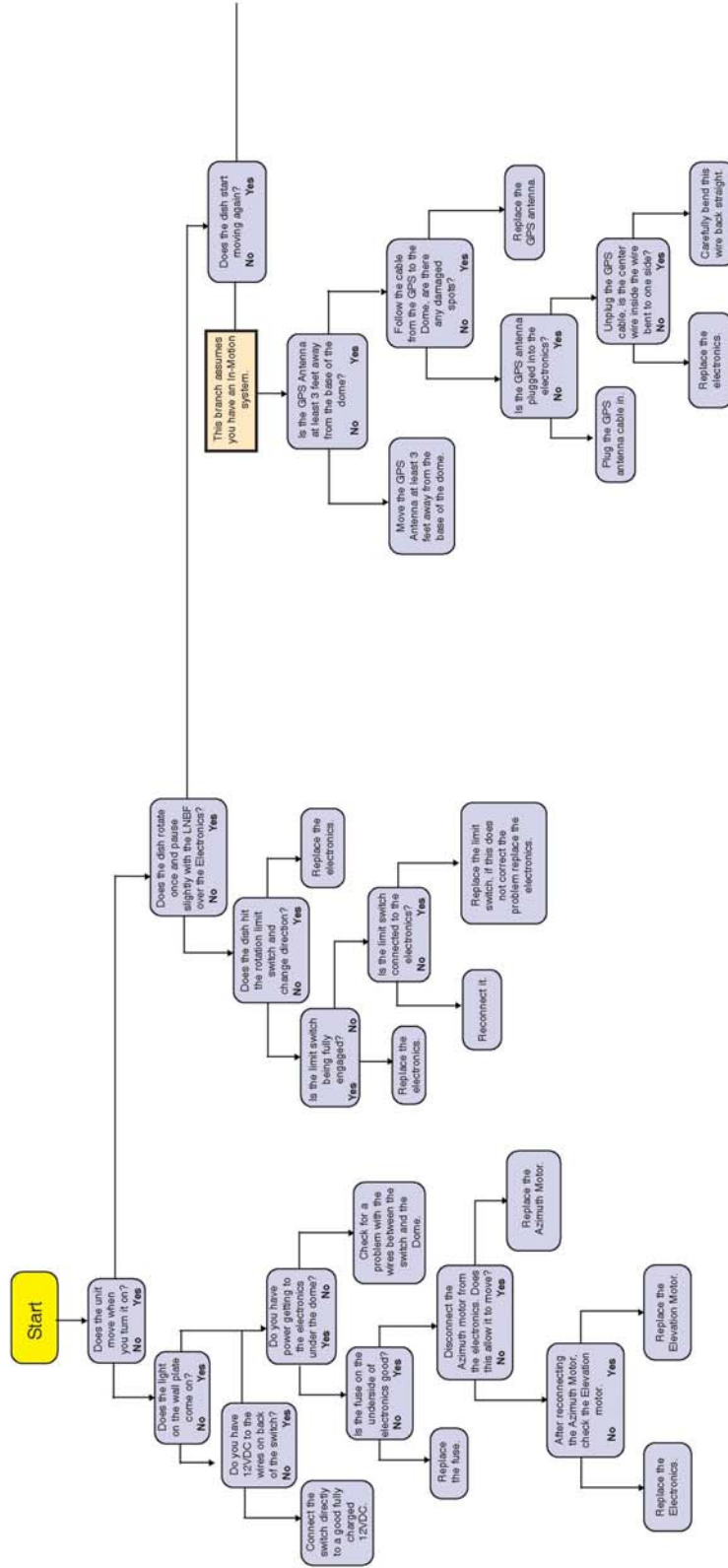

(cont.)

MV Troubleshooting Guide, (cont.)

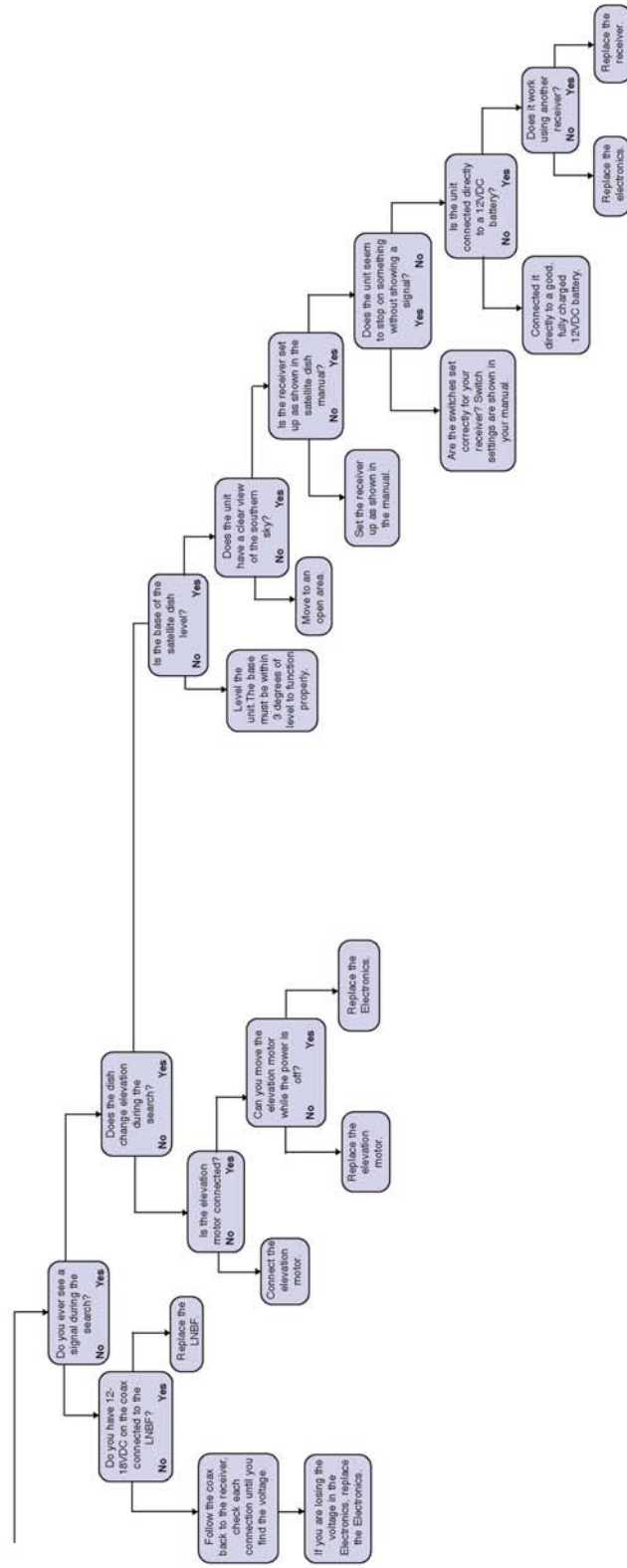

Winegard Company • 3000 Killewood St. • Burlington, IA 52801-2008 Printed in U.S.A. © Winegard Company 2005 www.winegard.com WC-042